

The image shows three red hats hanging on a white wall. The hats are arranged in a line, with the largest one in the foreground and two smaller ones behind it. A clothespin is attached to the wall on the right side, holding a wire that loops around the hats. The text is overlaid on the left side of the image.

# Solving Difficult Memory Performance Problems

Jiri Olsa  
Joe Mario  
January 27, 2017  
Red Hat Engineering

# Agenda

- Overview:
  - Where does my program get its memory from?
  - Types of expensive memory accesses
  - How to find out where they're happening?
  - How to resolve them?

# Background Basics

## System Layout

Node 0

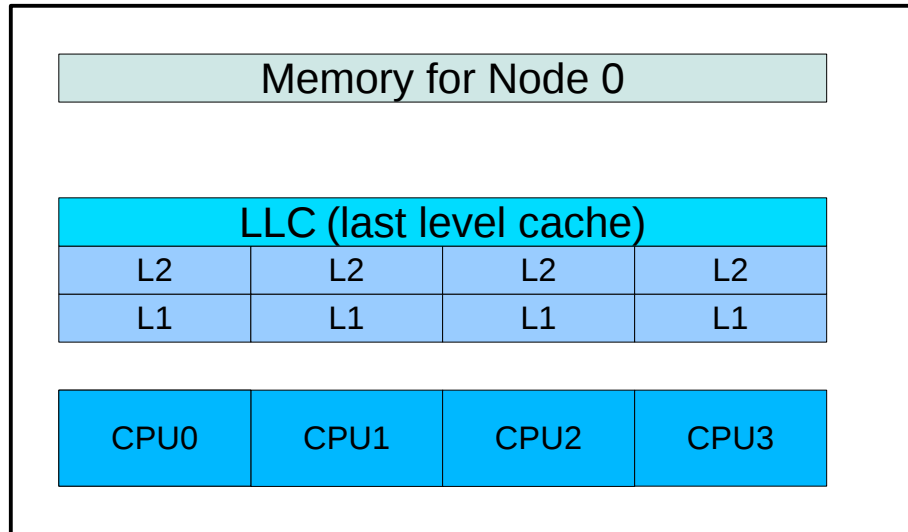

Node 1

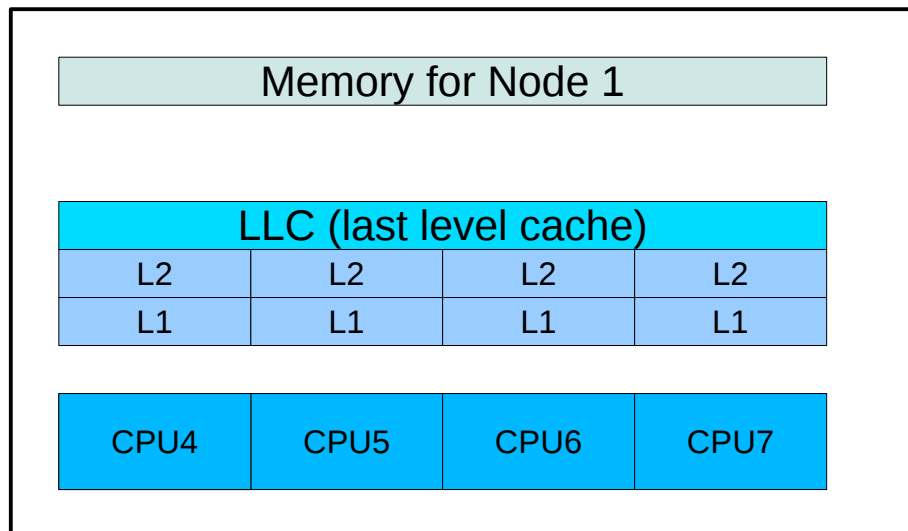

# Background Basics

## Resolving a memory access

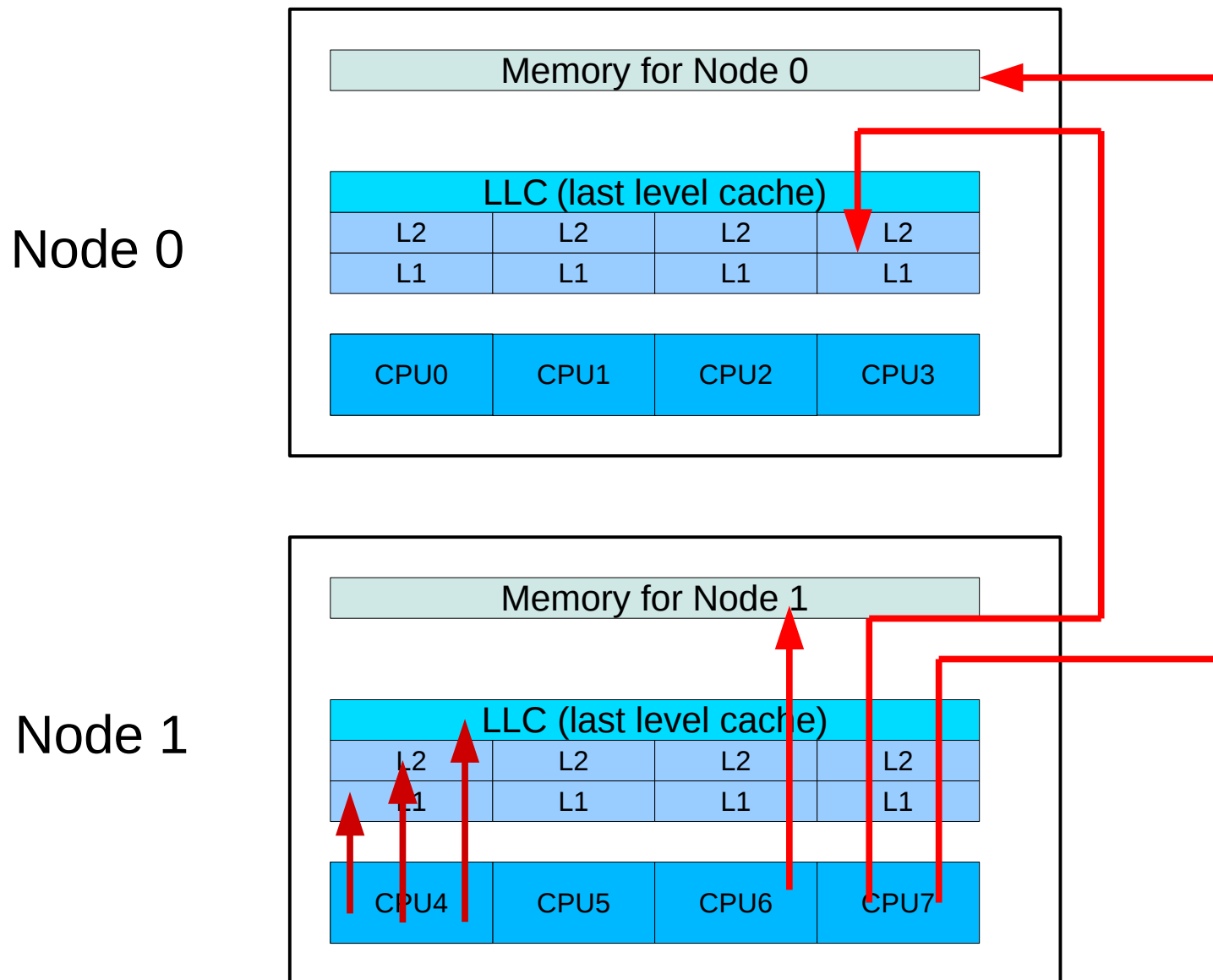

# Resolving a memory access – more expensive case.

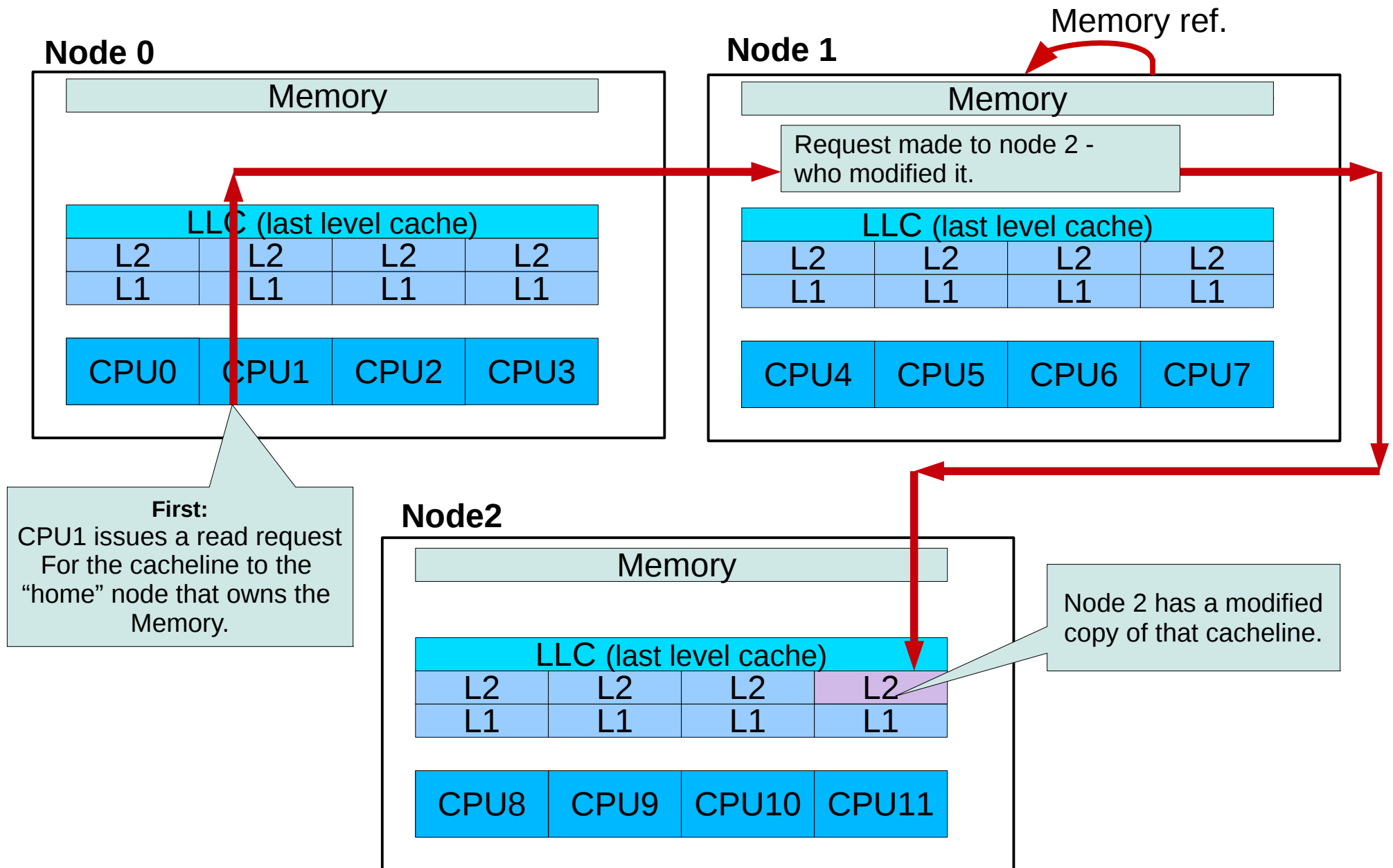

# In the ideal world:

All processes and memory are isolated to their own NUMA nodes.

Node 0

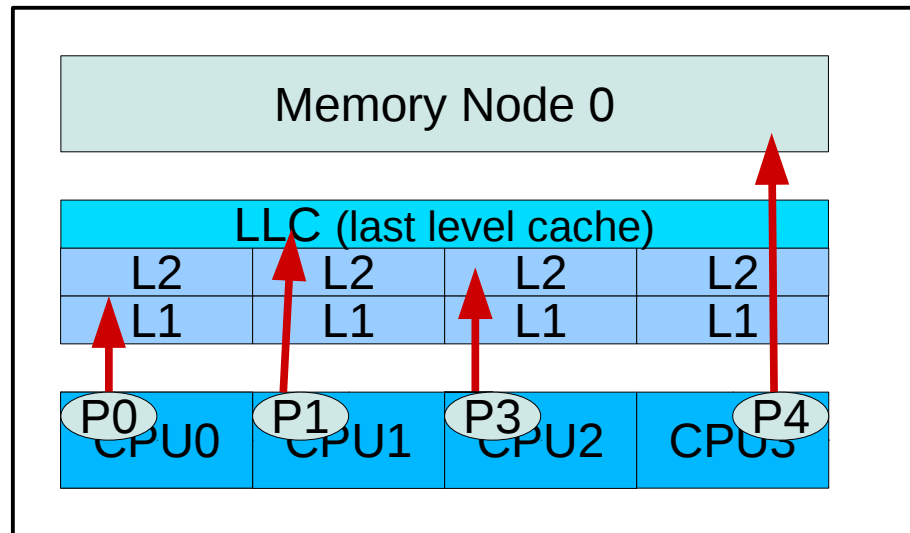

Node 1

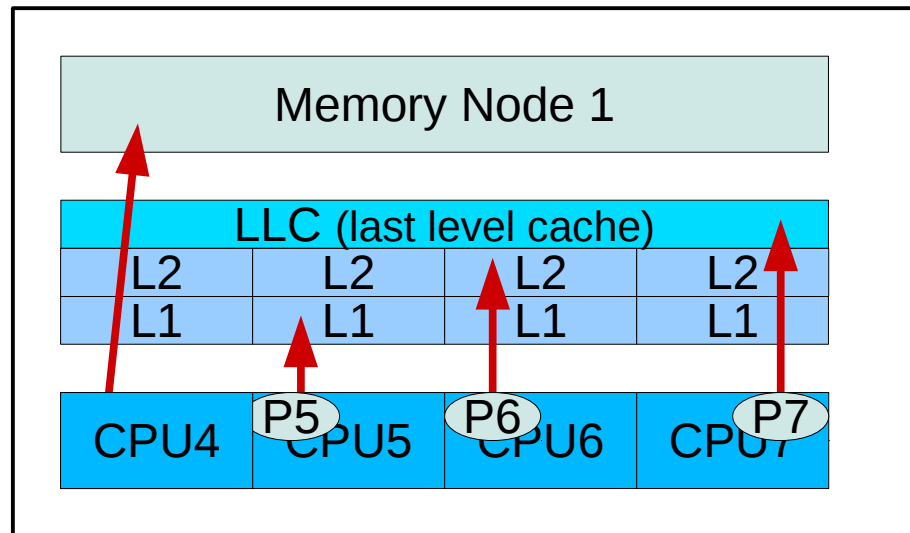

# In the “slightly less than” ideal world

“Sole user” of remote memory.

Not too bad if:

1. It fits in local node 1 cache
2. It stays in local node 1 cache
3. Your node is the only node accessing that memory.

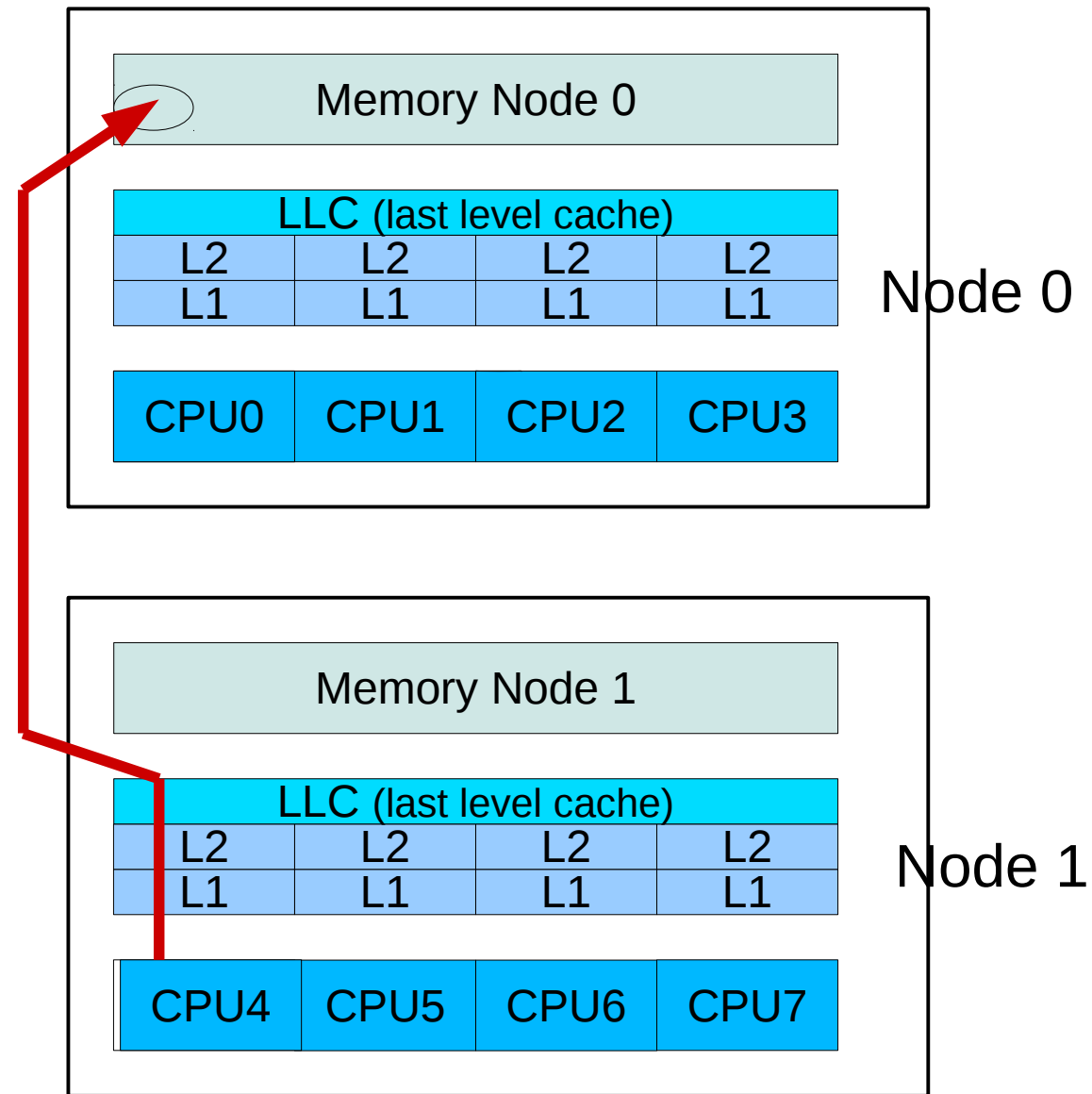

# False Sharing - Where it can hurt the most

Multiple NUMA nodes accessing same memory cacheline.

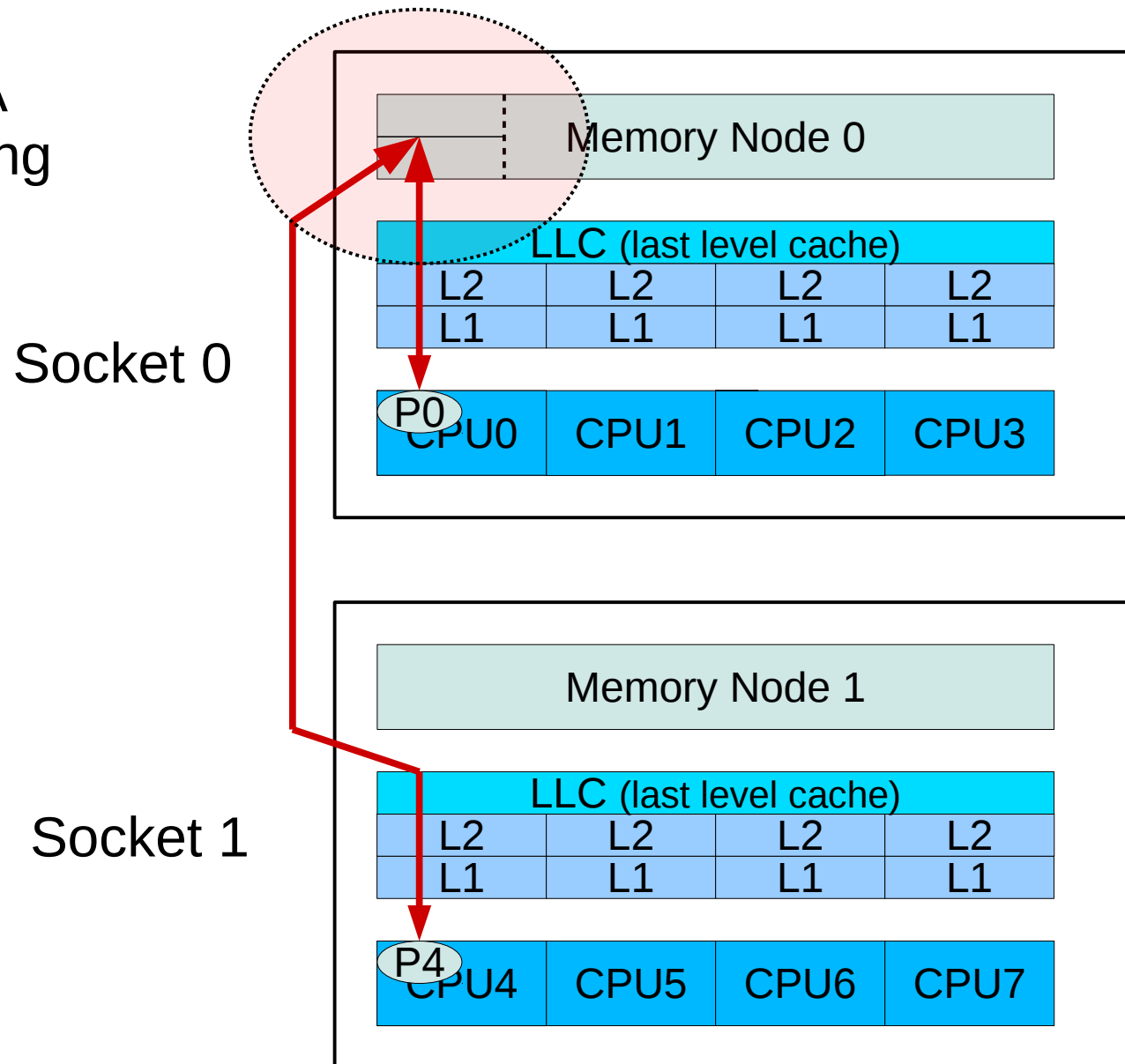



# Basic triage steps

What does my system layout look like?

- `lstopo`

Where is my program's memory located?

- `numastat`

Where are my program's threads executing?

- `ps -T -o pid,tid,psr,comm <pid>`
- Run “*top*”, then enter “*f*”, then select “*Last use cpu*” field.
- `trace-cmd`

Where is the memory my program is accessing?

- `perf mem`
- `numatop` [Intel]

# Istopo – to see system topology

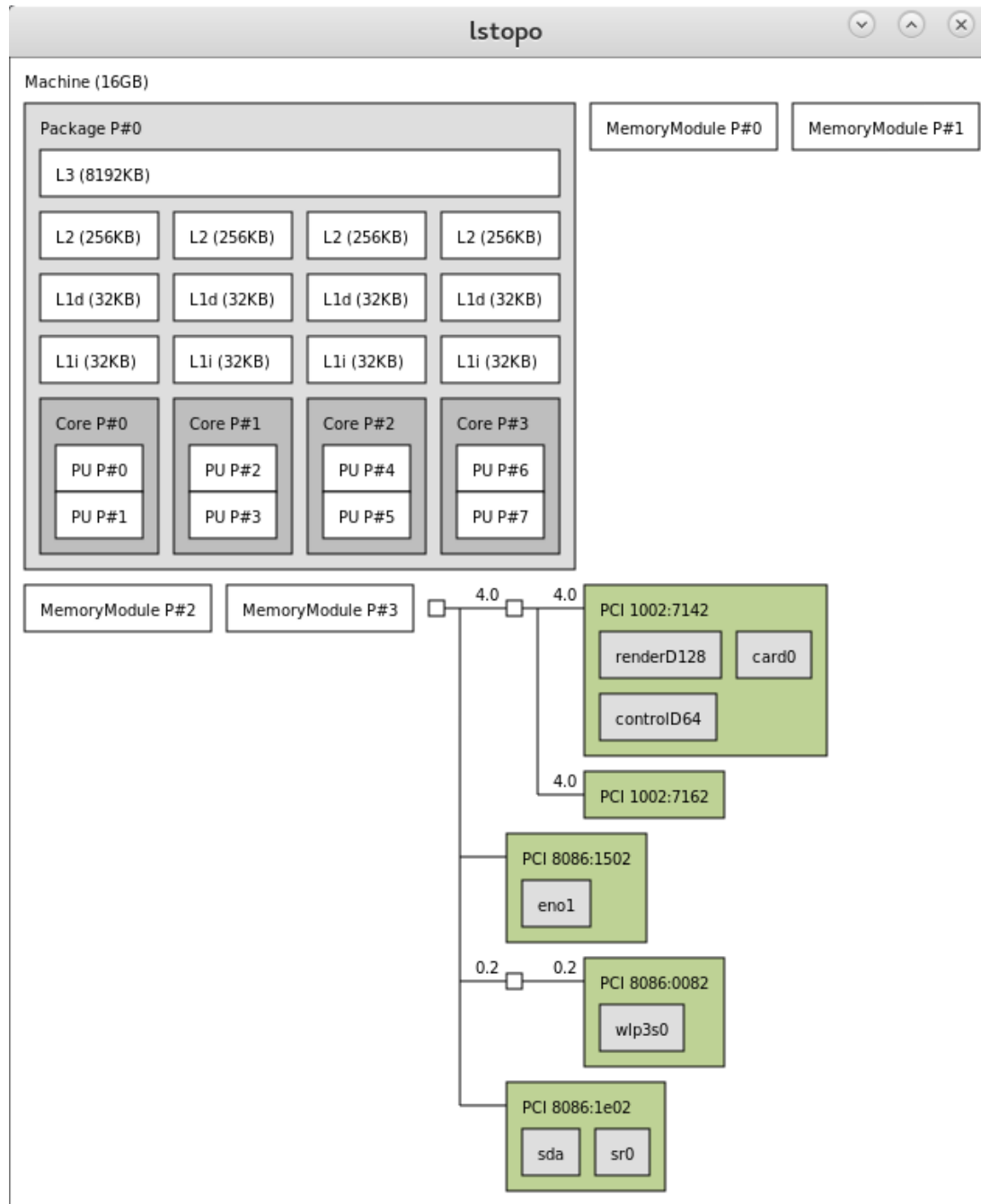

# Numastat

## Where is my program's memory?

Example:

Look at two unpinned instances of SPECjbb2005.

```
# numastat -c java
```

```
Per-node process memory usage (in MBs)
PID                Node 0 Node 1 Total
-----
31855 (java)       3160  6206  9366
31856 (java)       4891  4481  9372
-----
Total              8051 10687 18738
```

The memory for each pid is scattered across both numa nodes.

# Where is my program's memory? (continued)

Invoke it again, but with numactl pinning:

```
# numactl -m 0 -N 0 java <...>  
# numactl -m 1 -N 1 java <...>
```

```
# numastat -c java
```

Per-node process memory usage (in MBs)

PID	Node 0	Node 1	Total
-----	-----	-----	-----
30707 (java)	9359	11	9370
30708 (java)	2	9374	9375
-----	-----	-----	-----
Total	9361	9385	18745

The memory for each pid is confined to a numa node.

# Unanswered questions

- numastat shows program's memory location, but not threads.
- The key question: Where are my threads executing and are they contending for the same memory/cachelines?
- If your program spans multiple numa nodes:
  - Are my threads accessing memory on remote nodes?
  - If so, how often?
  - Are they in contention for memory locations with other threads (E.G. false sharing)?
  - With multi-threads or shared memory, performance can take a bit hit.

# Look at a simple example false sharing example:

## Two flavors of a basic data structure

```
struct false_sharing_buf {           // Reader & writer
    long writer;                     // fields together
    long reader;
} buf ;
```

```
struct uncontended_buf {           // Writer fields
    long writer;                     // separated from
    long pad[7];                    // writer field
    long reader1;
    long pad2[7];
} buf;
```

# In memory, first struct:

Reader thread

Writer thread

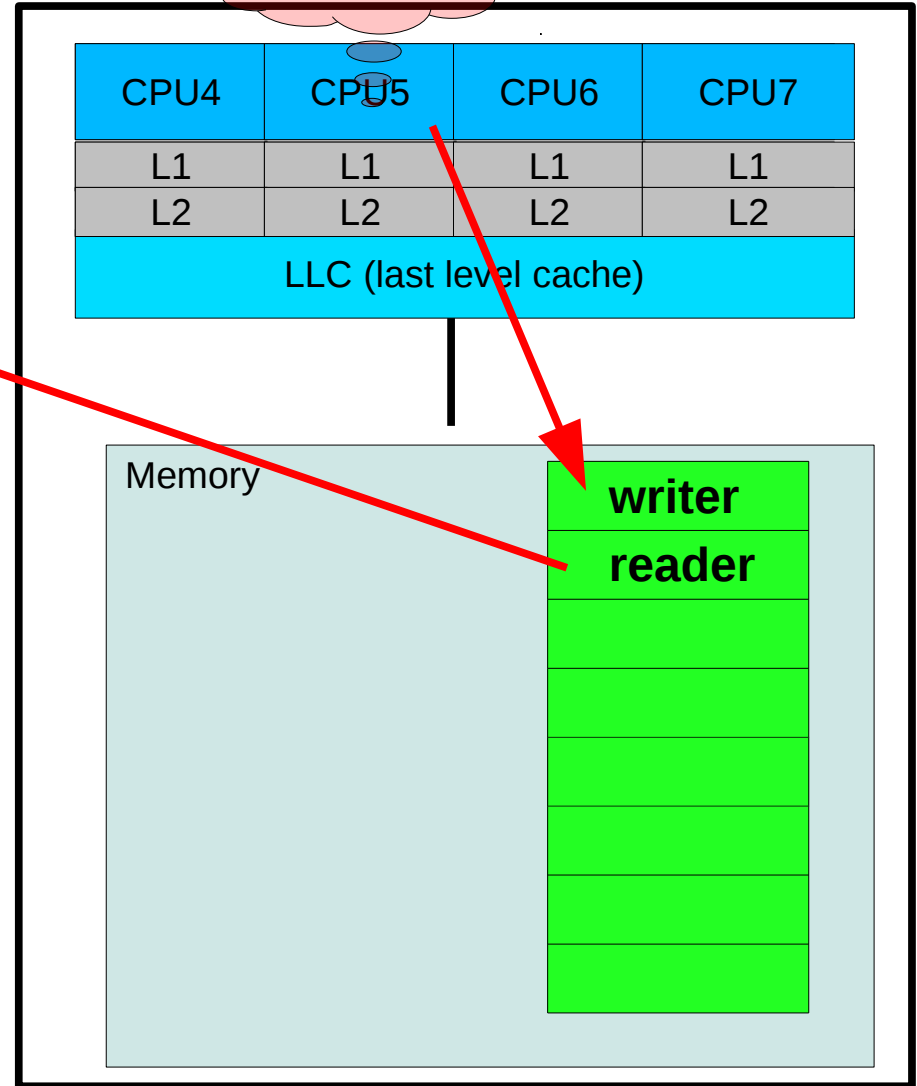
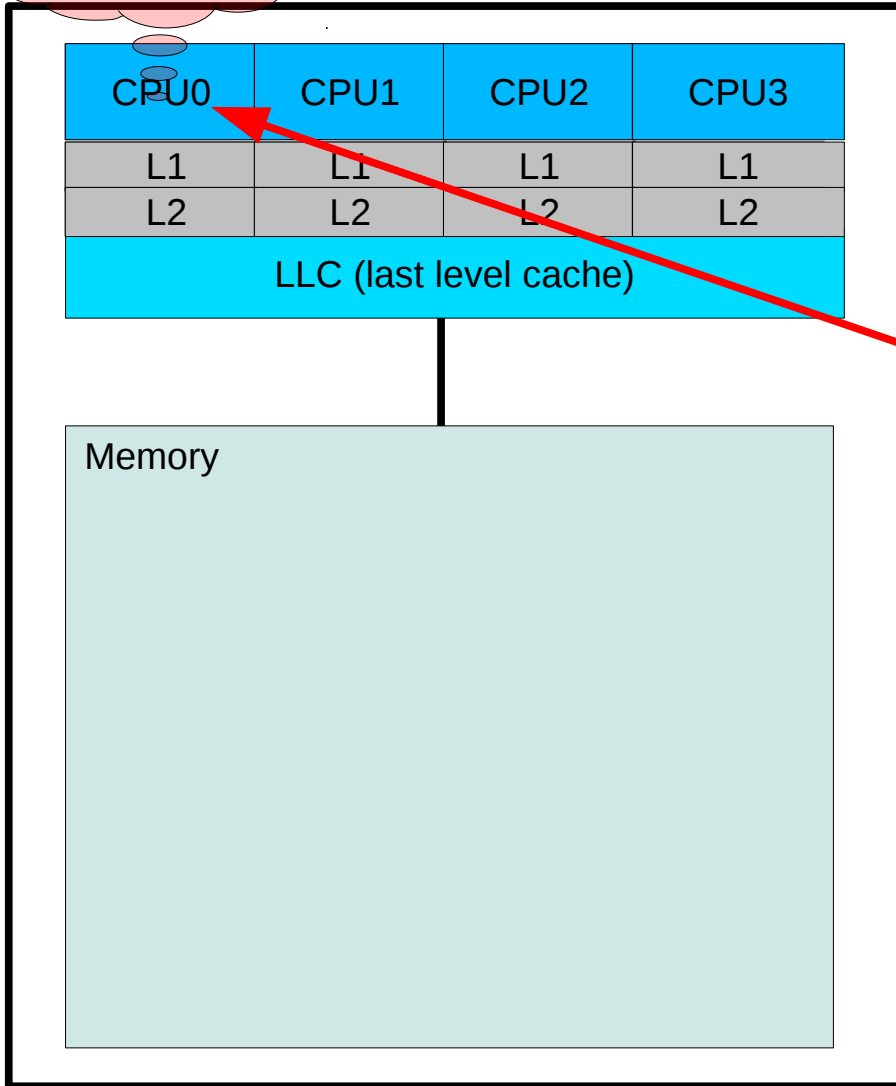

# In memory, second struct:

Reader thread

Writer thread

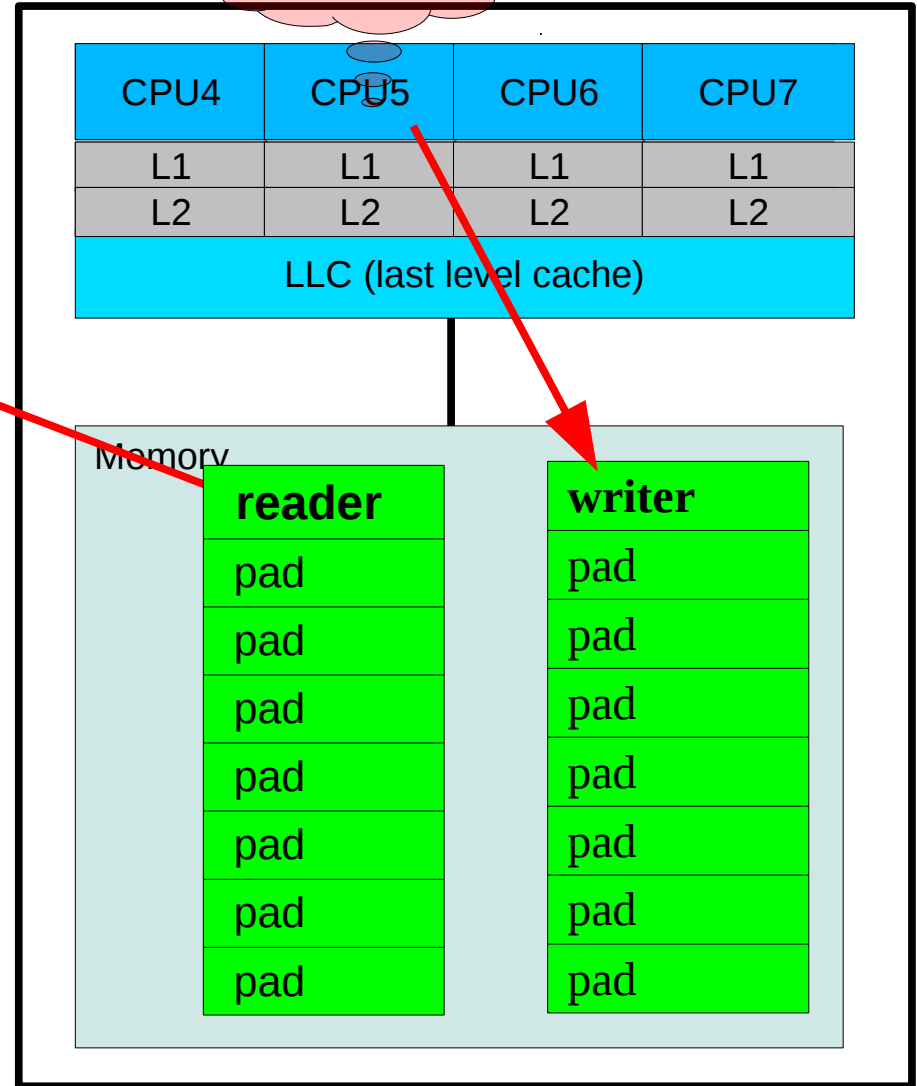
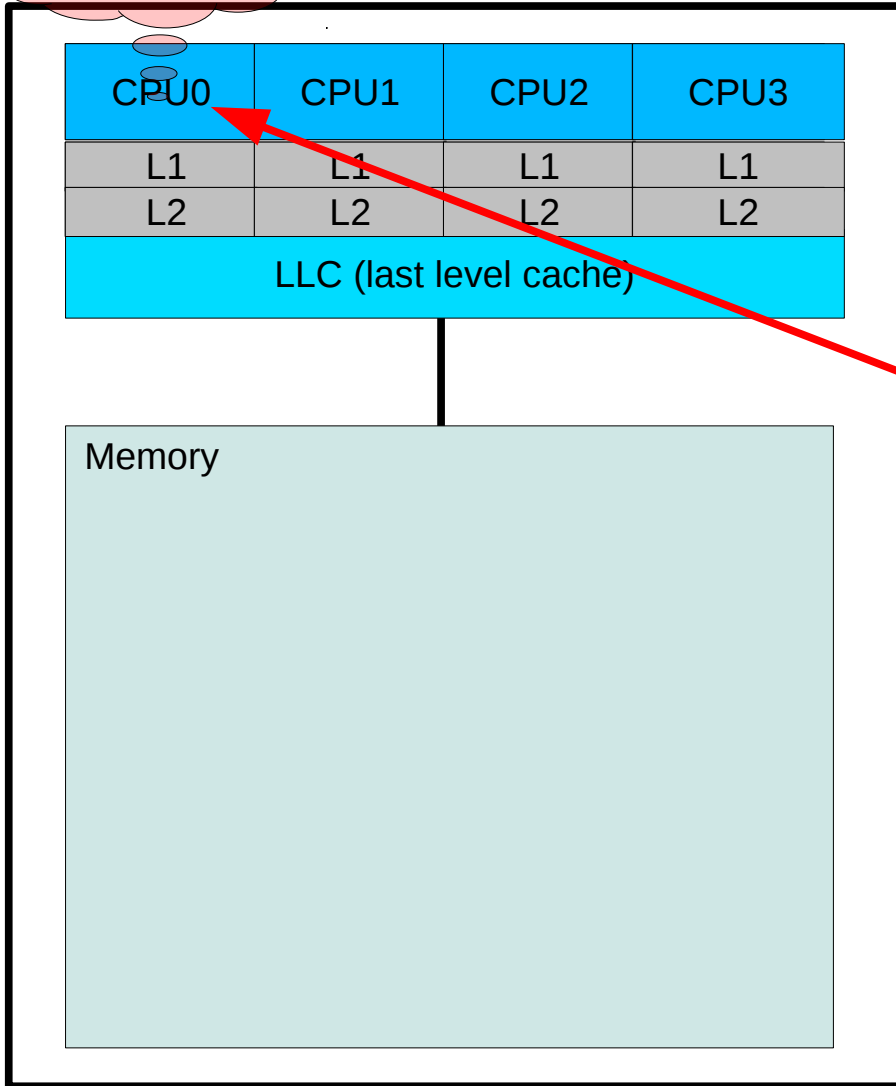



# Run it through a simple loop:

- Two threads running in parallel.
- Assume buf struct aligned on 64-byte boundary.
- loop-cnt = 500,000,000

```
/* Writer thread on node 0 */  
for (i = 0; i < loop-cnt; ++i) {  
    buf.writer += 1;  
    asm volatile("rep; nop")  
}
```

```
/* Reader thread on node 1 */  
for (i = 0; i < loop-cnt; ++i) {  
    var = buf.reader;  
    asm volatile("rep; nop")  
}
```

**Question:**  
How fast can the reader thread complete the loop?

**Answer:**  
When “buf.writer” is in own cacheline, the reader thread finishes loop **2-4X** faster on 2 node system,  
**And up to 20X** faster with multiple readers on a 4 node system.

# Simple false sharing

Reader Thread

Writer Thread

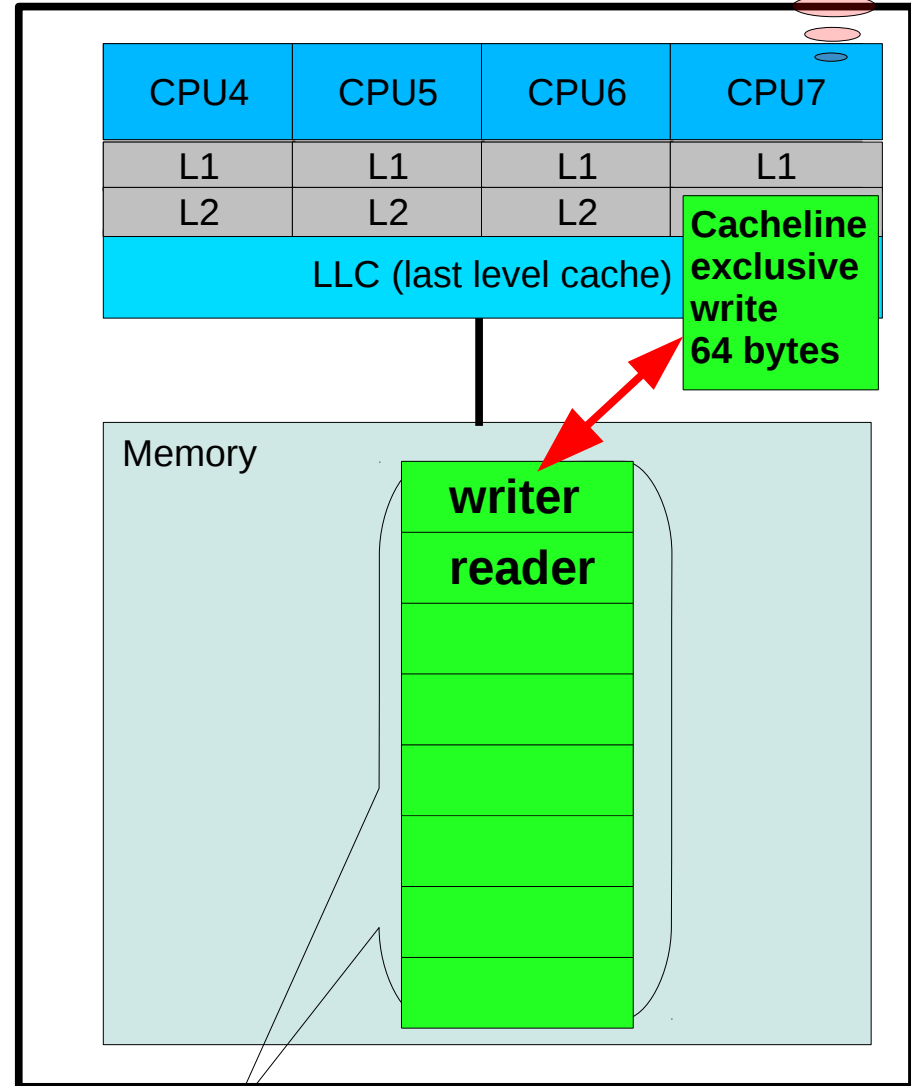
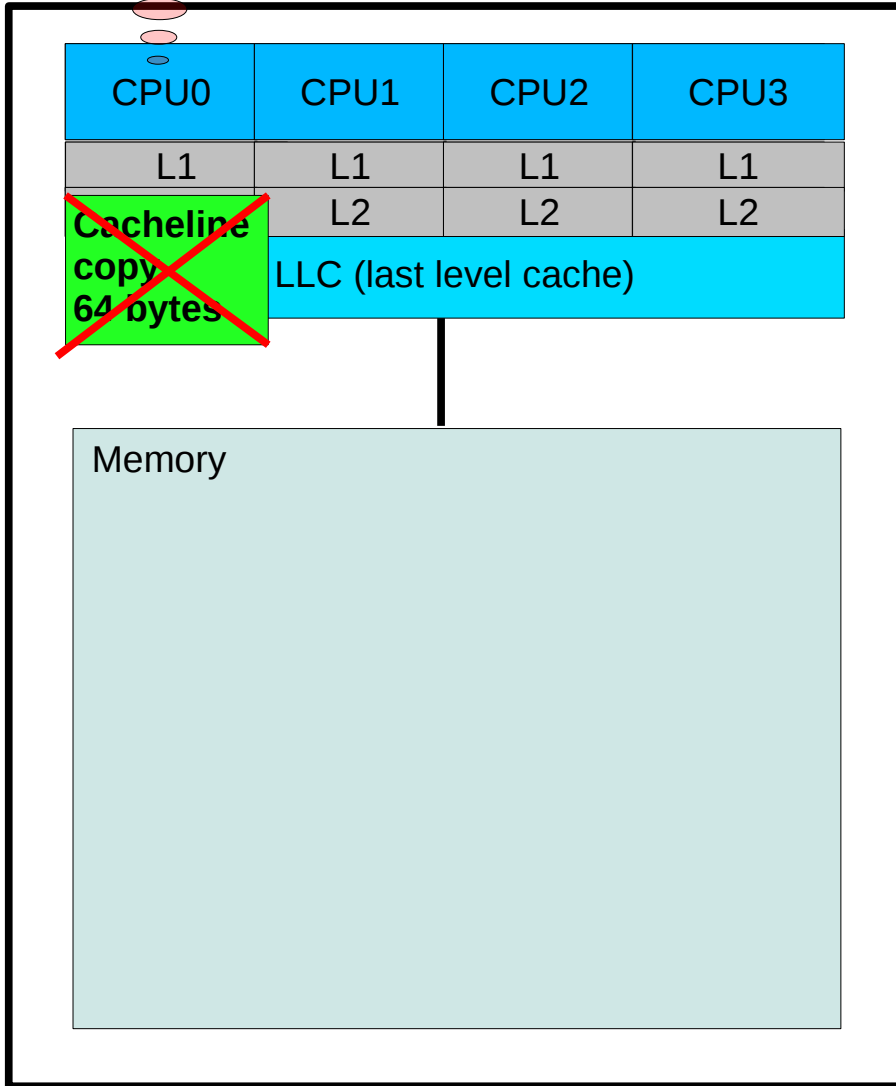

64-byte cache line

# Looking a little closer:

- Every time buf.writer is modified:
  - The reader thread's cacheline copy is disguardred.
  - Must go back for an updated cacheline copy.
  - Or get back in line if other threads are contending for the cacheline.
- With lots of threads and/or large systems:
  - It takes increasingly longer for any one of them to access the cacheline.
  - Often lots longer

# As your application gets larger... Lots of contention.

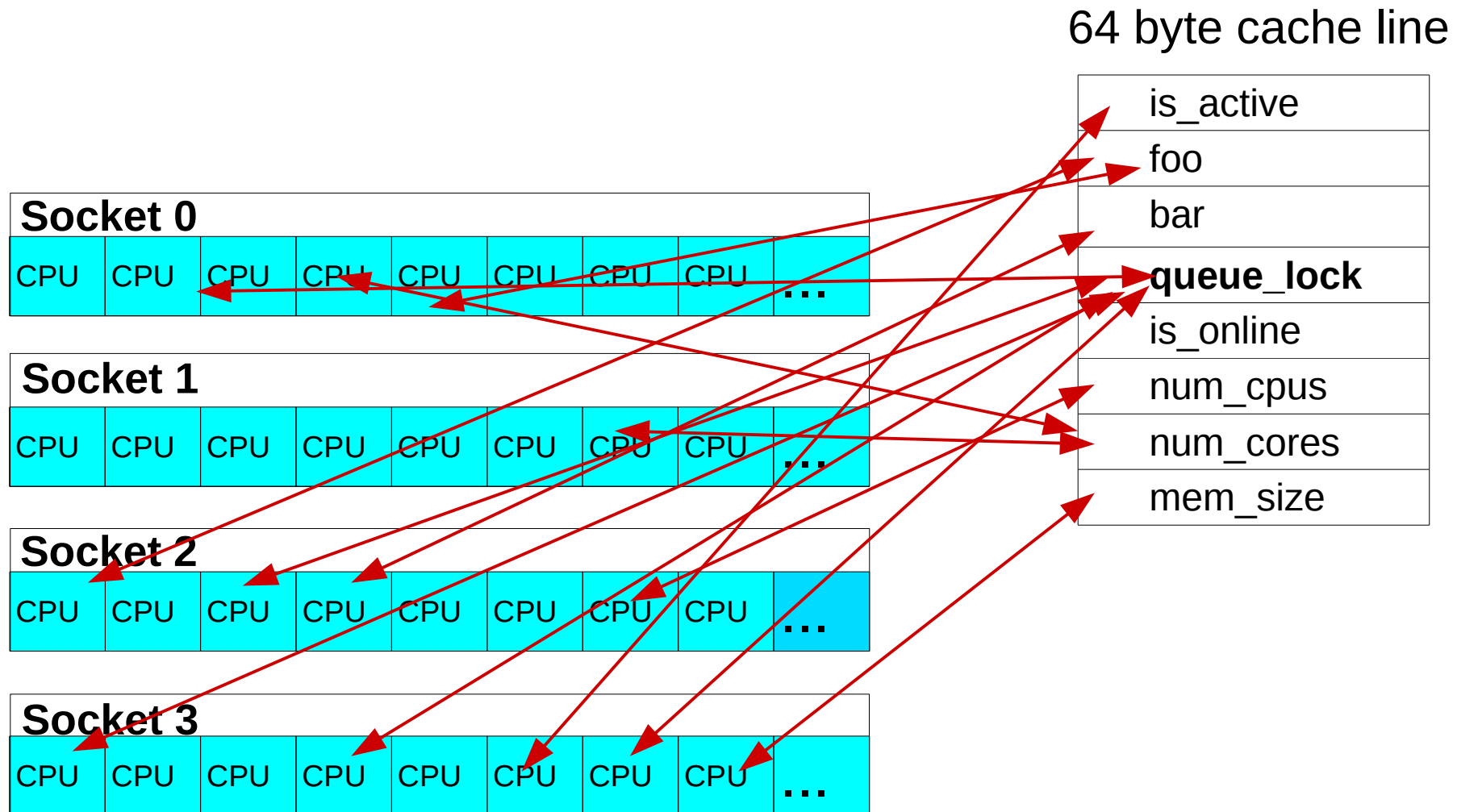

# CPU cacheline false sharing

- Multiple threads accessing/modifying same cacheline.
- Multiple processes to same cacheline in shared memory.
- Sharing cachelines across numa nodes costly.
- As are atomic memory operations, e.g. locked instructions, to same cachelines
- Magnified on larger systems (8 and 16 numa nodes)

# How to detect and find this?

New addition to the Linux perf tool:

**perf c2c**

“c2c” stands for “*cache to cache*”

Developed at Red Hat

Recently merged upstream into 4.9-rc2

Look for it in a future RHEL 7.x (hoping for 7.4).

*Use on Intel IVB or newer cpus*

# At a high level, “perf c2c” provides:

- 1) All the readers and writers to the contended cachelines.
- 2) The cacheline’s virtual addr.
- 3) The offsets into the cachelines for those accesses.
- 4) The pid, tid, instruction addr, function name, image filename.
- 5) The source file and line numbers.

# At a high level, “perf c2c” provides:

- 1) The node & cpu numbers where the accesses are occurring.
- 2) The average load latency for the loads.
- 3) Ability to see when hot variables are sharing a cacheline.
- 4) Ability to see unaligned hot data structs spilling into multiple cachelines.



# PERF C2C

- record/report command
  - `perf c2c record ...`
  - `perf c2c report ...`
- sample INTEL memory events
- load/store memory
  - virtual address
  - type
  - latency (cycles)

# PERF RECORD

```
perf c2c record [options] -- [record options] <command>
```

# PERF RECORD

```
perf c2c record [options] -- [record options] <command>
```

- c2c record options:
  - -u,-k,-l <latency>

# PERF RECORD

```
perf c2c record [options] -- [record options] <command>
```

- c2c record options:
  - -u,-k,-l <latency>
- standard record options:
  - a -p -u -g --callgraph -F ...

# PERF RECORD

```
perf c2c record [options] -- [record options] <command>
```

- c2c record options:
  - -u,-k,-l <latency>
- standard record options:
  - a -p -u -g --call-graph -F ...
- command:
  - sleep ..., perf bench sched ...

# PERF RECORD

- system wide, latency, user space, callchains:

```
perf c2c record -u -l 50 -- -a -g sleep 10
```

- specific process, user space, callchains:

```
perf c2c record -u -- -p 1234 -g
```

- system wide, kernel space, latency/frequency:

```
perf c2c record -k -l 100 -- -F 80000 -a
```

- system wide, system wide, workload:

```
perf c2c record -- -a perf bench sched pipe
```

# PERF C2C REPORT

- sorts and displays data
- TUI/stdio versions

```
perf c2c report --stats
```

```
perf c2c report
```

```
perf c2c report [--stdio] > out.txt
```

# REPORT – STATS

=====  
Trace Event Information  
=====

Total records : 64860643  
Locked Load/Store Operations : 5015391  
Load Operations  
Loads - uncacheable  
Loads - IO  
Loads - Miss  
Loads - no mapping : 64230  
Load Fill Buffer Hit : 1486059  
Load L1D hit : 1716191  
Load L2D hit : 515375  
Load LLC hit : 297056  
Load Local HITM : 67581  
Load Remote HITM : 788  
Load Remote HIT : 338  
Load Local DRAM : 10  
Load Remote DRAM : 432  
Load MESI State Exclusive : 388  
Load MESI State Shared : 54  
Load LLC Misses : 1568  
LLC Misses to Local DRAM : 0.6%  
LLC Misses to Remote DRAM : 27.6%  
LLC Misses to Remote cache (HIT) : 21.6%  
LLC Misses to Remote cache (HITM) : 50.3%  
Store Operations : 60346159  
Store - uncacheable : 0  
Store - no mapping : 39174  
Store L1D Hit : 58855217  
Store L1D Miss : 1451768  
No Page Map Rejects : 1699  
Unable to parse data source : 0

Load Local HITM	:	67581
Load Remote HITM	:	788



# Scenario 1: First version of data structure

Reader thread

Writer thread

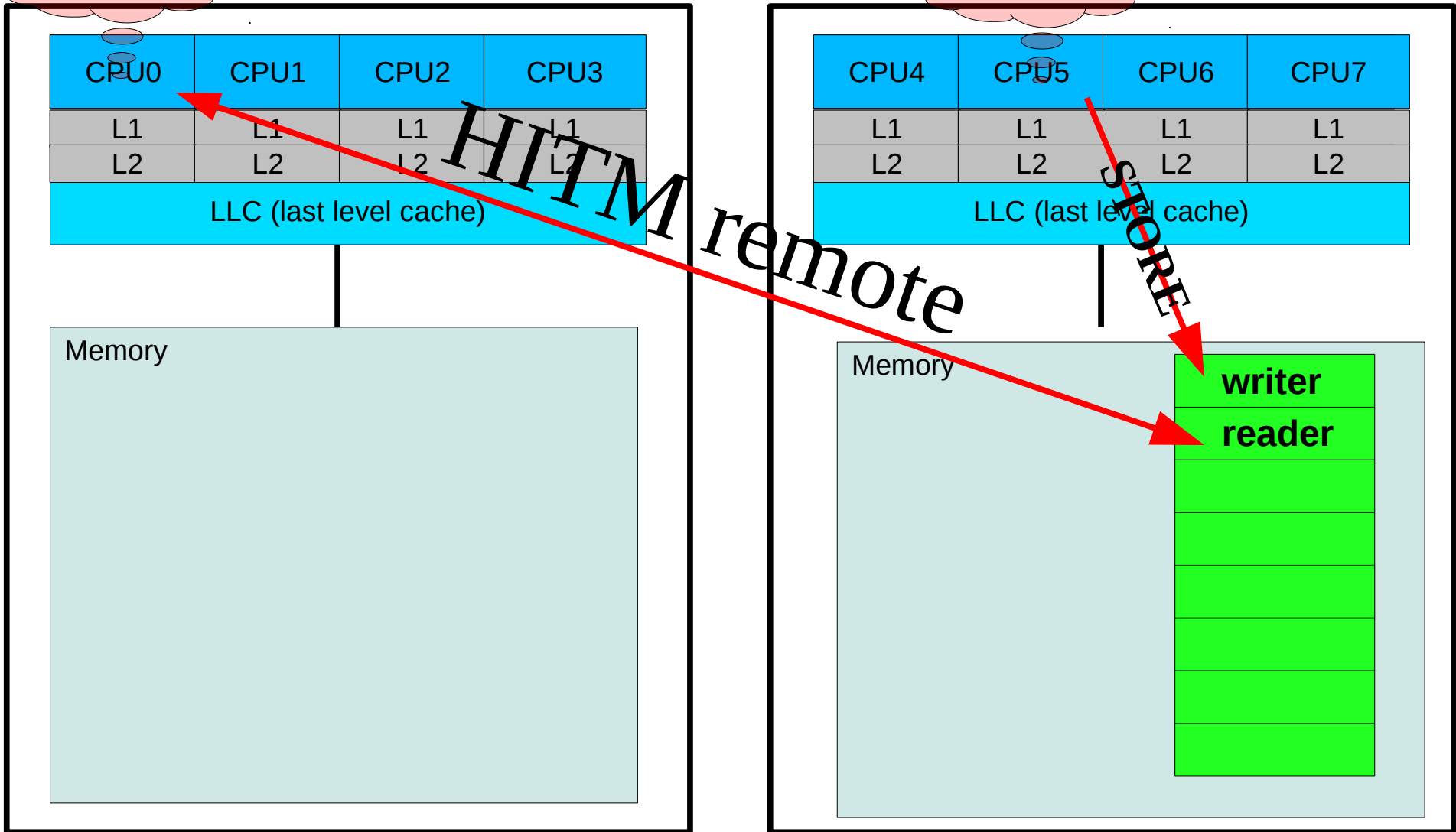

# PERF C2C REPORT

- display cachelines that contains:  
**HITMs**  
**STOREs**
- 2 tables:  
cachelines list  
single cacheline details

# REPORT – SHARED CACHE LINES

```

=====
Shared Data Cache Line Table
=====
#
#
# Index      Cacheline      Total      Tot  ----- LLC Load Hitm -----  Store Reference -----  Load Dram -----  LLC      Total      ----- Core Load Hit -----  -- LLC Load Hit --
#           .....      records      Hitm  Total    Lcl    Rmt    Total    L1Hit  L1Miss  Lcl    Rmt    Ld Miss  Loads    FB      L1      L2      Llc      Rmt
#           .....      .....      .....  .....  .....  .....  .....  .....  .....  .....  .....  .....  .....  .....  .....  .....  .....  .....  .....
#
0 0xffff880477000140 12183  3.06%  363  363  0  1001  961  40  0  0  0  11182  1908  5885  2572  454  0
1 0xffff880277400140 11033  2.66%  316  316  0  1037  990  47  0  0  0  9996  1335  5509  2367  469  0
2 0xffff880477000ec0 12142  2.07%  246  246  0  1019  994  25  0  0  0  11123  1748  6049  2611  469  0
3 0xffff880277400ec0 10776  2.07%  245  245  0  993  965  28  0  0  0  9783  1354  5529  2238  417  0
4 0xffff8801aa0dc780 272  0.26%  31  31  0  128  104  24  0  0  0  144  63  7  43  0  0
5 0xffff880277c19740 192  0.24%  29  29  0  93  87  6  0  0  0  99  25  21  24  0  0
6 0xffff88046fa91a00 189  0.18%  21  21  0  108  88  20  0  0  0  81  36  10  14  0  0
7 0xffff88046fa92000 147  0.18%  21  21  0  88  72  16  0  0  0  59  22  5  11  0  0
8 0xffff88047fad9700 153  0.17%  20  20  0  109  109  0  0  0  0  44  2  7  15  0  0
9 0xffff88047fa59740 144  0.16%  19  19  0  72  70  2  0  0  0  72  22  11  20  0  0
10 0xffff88047fc59740 160  0.16%  19  19  0  93  85  8  0  0  0  67  19  12  17  0  0
11 0xffff8801aa0dd600 168  0.13%  16  16  0  101  92  9  0  0  0  67  26  11  14  0  0
12 0xffff8801aa0de800 157  0.13%  16  16  0  86  76  10  0  0  0  71  28  9  18  0  0
13 0xffff88046fc08980 211  0.13%  16  16  0  100  83  17  0  0  0  111  51  10  34  0  0
14 0xffff8801aa0dc600 199  0.13%  15  15  0  125  106  19  0  0  0  74  40  7  12  0  0
15 0xffff8801aa0de780 230  0.13%  15  15  0  116  91  25  0  0  0  114  61  12  26  0  0
16 0xffff880277bd9700 166  0.13%  15  15  0  132  129  3  0  0  0  34  0  4  15  0  0
17 0xffff880277c59700 147  0.13%  15  15  0  111  108  3  0  0  0  36  0  10  11  0  0
18 0xffff88046fa92180 227  0.13%  15  15  0  113  93  20  0  0  0  114  56  11  32  0  0
19 0xffff88047fad9740 177  0.13%  15  15  0  91  84  7  0  0  0  86  32  17  22  0  0
20 0xffff880277bd9780 164  0.12%  14  14  0  50  37  13  0  0  0  114  82  6  12  0  0
21 0xffff88046fa90180 187  0.12%  14  14  0  112  89  23  0  0  0  75  29  8  24  0  0
22 0xffff88046fa91e00 235  0.12%  14  14  0  145  142  3  0  0  0  90  30  27  19  0  0
23 0xffff88046fc09480 157  0.12%  14  14  0  61  61  0  0  0  0  96  48  16  18  0  0
24 0xffff88046fc09c80 177  0.12%  14  14  0  64  64  0  0  0  0  113  46  29  24  0  0
25 0xffff88047fbd9780 142  0.12%  14  14  0  50  44  6  0  0  0  92  57  8  13  0  0
26 0xffff8801aa0dd780 137  0.11%  13  13  0  86  71  15  0  0  0  51  22  5  11  0  0

```

# REPORT – SHARED CACHE LINES

```

=====
Shared Data Cache Line Table
=====

```

#	#	#	#	Total	Tot	LLC Load Hitm	Store Reference	Load Dram	LLC	Total	Core Load Hit	LLC Load Hit							
#	Index	Cacheline	records	Hitm	Total	Lcl	Rmt	Total	LlHit	LlMiss	Lcl	Rmt	Ld Miss	Loads	FB	L1	L2	Llc	Rmt
	0	0xffff880477000140	12183	3.06%	363	363	0	1001	961	40	0	0	0	11182	1908	5885	2572	454	0
	1	0xffff880277400140	11033	2.66%	316	316	0	1037	990	47	0	0	0	9996	1335	5509	2367	469	0
	2	0xffff880477000ec0	12142	2.07%	246	246	0	1019	994	25	0	0	0	11123	1748	6049	2611	469	0
	3	0xffff880277400ec0	10776	2.07%	245	245	0	993	965	28	0	0	0	9783	1354	5529	2238	417	0
	4	0xffff8801aa0dc780	272	0.26%	31	31	0	128	104	24	0	0	0	144	63	7	43	0	0
	5	0xffff880277c19740	192	0.24%	29	29	0	93	87	6	0	0	0	99	25	21	24	0	0
	6	0xffff88046fa91a00	189	0.18%	21	21	0	108	88	20	0	0	0	81	36	10	14	0	0
	7	0xffff88046fa92000	147	0.18%	21	21	0	88	72	16	0	0	0	59	22	5	11	0	0
	8	0xffff88047fad9700	153	0.17%	20	20	0	109	109	0	0	0	0	44	2	7	15	0	0
	9	0xffff88047fa59740	144	0.16%	19	19	0	72	70	2	0	0	0	72	22	11	20	0	0
	10	0xffff88047fc59740	160	0.16%	19	19	0	93	85	8	0	0	0	67	19	12	17	0	0

#	#	#	Total	Tot	LLC Load Hitm	Store Reference				
#	Index	Cacheline	records	Hitm	Total	Lcl	Rmt	Total	LlHit	LlMiss
	0	0xffff880477000140	12183	3.06%	363	363	0	1001	961	40
	1	0xffff880277400140	11033	2.66%	316	316	0	1037	990	47
	2	0xffff880477000ec0	12142	2.07%	246	246	0	1019	994	25
	3	0xffff880277400ec0	10776	2.07%	245	245	0	993	965	28
	4	0xffff8801aa0dc780	272	0.26%	31	31	0	128	104	24

# REPORT – SHARED CACHE LINES

=====  
 Shared Data Cache Line Table  
 =====

#	#	#	Total	Tot	LLC	Load	Hitm	-----	Store	Reference	---	Load	Drum	---	LLC	Total	---	Core	Load	Hit	---	LLC	Load	Hit	---
#	Index	Cacheline	records	Hitm	Total	Lcl	Rmt	Total	LlHit	LlMiss	Lcl	Rmt	Ld Miss	Loads	FB	L1	L2	Llc	Rmt						
0	0	0xffff880477000140	12183	3.06%	363	363	0	1001	961	40	0	0	0	11182	1908	5885	2572	454	0						
1	1	0xffff880277400140	11033	2.66%	316	316	0	1037	990	47	0	0	0	9996	1335	5509	2367	469	0						
2	2	0xffff880477000ec0	12142	2.07%	246	246	0	1019	994	25	0	0	0	11123	1748	6049	2611	469	0						
3	3	0xffff880277400ec0	10776	2.07%	245	245	0	993	965	28	0	0	0	9783	1354	5529	2238	417	0						
4	4	0xffff8801aa0dc780	272	0.26%	31	31	0	128	104	24	0	0	0	144	63	7	43	0	0						
5	5	0xffff880277c19740	192	0.24%	29	29	0	93	87	6	0	0	0	99	25	21	24	0	0						
6	6	0xffff88046fa91a00	189	0.18%	21	21	0	108	88	20	0	0	0	81	36	10	14	0	0						
7	7	0xffff88046fa92000	147	0.18%	21	21	0	88	72	16	0	0	0	59	22	5	11	0	0						
8	8	0xffff88047fad9700	153	0.17%	20	20	0	109	109	0	0	0	0	44	2	7	15	0	0						
9	9	0xffff88047fa59740	144	0.16%	19	19	0	72	70	2	0	0	0	72	22	11	20	0	0						
10	10	0xffff88047fc59740	160	0.16%	19	19	0	93	85	8	0	0	0	67	19	12	17	0	0						
11	11	0xffff8801aa0dd600	168	0.13%	16	16	0	101	92	9	0	0	0	67	26	11	14	0	0						
12	12	0xffff8801a																							
13	13	0xffff88046																							
14	14	0xffff8801a																							
15	15	0xffff8801a																							
16	16	0xffff88027																							
17	17	0xffff88027																							
18	18	0xffff88046																							
19	19	0xffff88047																							
20	20	0xffff88027																							
21	21	0xffff88046																							
22	22	0xffff88046																							
23	23	0xffff88046																							
24	24	0xffff88046																							
25	25	0xffff88047																							
26	26	0xffff8801a																							

# REPORT – DISTRIBUTION PARETO

```

=====
Shared Cache Line Distribution Pareto
=====
#
# ----- HITM ----- -- Store Refs --      Data address
# Num      Rmt      Lc1      L1 Hit  L1 Miss      Offset
# .....
#
-----
0      1310      1630      1583      999      0x602100
-----
0.76%  0.00%  0.00%  0.00%      0x0  108517      0x400b7a      597      0      1158      1  [.] lock_thd      a.out  false_sharing_example.c:134  0
0.15%  0.00%  66.08%  0.00%      0x0  108517      0x400b61      2780     0      1569      1  [.] lock_thd      a.out  false_sharing_example.c:132  0
0.00%  0.00%  33.92%  100.00%     0x0  108517      0x400b85      0        0      0        1  [.] lock_thd      a.out  false_sharing_example.c:134  0
32.67% 29.02%  0.00%  0.00%      0x8  108517      0x400bab      1100     498    1021     12  [.] reader_thd     a.out  false_sharing_example.c:145  0  1  2  3
31.68% 41.23%  0.00%  0.00%      0x10 108517      0x400bab      1075     542    1074     11  [.] reader_thd     a.out  false_sharing_example.c:145  0  1  2  3
34.73% 29.75%  0.00%  0.00%      0x18 108517      0x400bab      1008     429    1077     12  [.] reader_thd     a.out  false_sharing_example.c:145  0  1  2  3
-----
1      1240      1515      3088      178      0x602140
-----
0.16%  0.00%  97.51%  0.00%      0x0  108517      0x400b55      1379     0      1441     1  [.] lock_thd      a.out  false_sharing_example.c:131  0
0.00%  0.00%  2.49%  100.00%     0x0  108517      0x400b73      0        0      0        1  [.] lock_thd      a.out  false_sharing_example.c:133  0
32.66% 30.43%  0.00%  0.00%      0x8  108517      0x400ba0      994      383    998     12  [.] reader_thd     a.out  false_sharing_example.c:144  0  1  2  3
31.29% 38.02%  0.00%  0.00%      0x10 108517      0x400ba0      1046     423    976     11  [.] reader_thd     a.out  false_sharing_example.c:144  0  1  2  3
35.89% 31.55%  0.00%  0.00%      0x18 108517      0x400ba0      999      384    1028     12  [.] reader_thd     a.out  false_sharing_example.c:144  0  1  2  3
-----
2      1      2      2      0      0xffff887bfd04b100
-----
100.00% 100.00%  0.00%  0.00%      0x0  108517  0xfffffffff810c7f0f      2541     124    474     9  [k] update_cfs_shares [kernel.vmlinux] compiler.h:243  0  1  3
0.00%  0.00%  50.00%  0.00%      0x0  108517  0xfffffffff810cbd10      0        0      767     3  [k] task_tick_fair   [kernel.vmlinux] atomic64_64.h:45  0  1  2
0.00%  0.00%  50.00%  0.00%      0x0  0      0xfffffffff810c4bb4      0        0      0        1  [k] update_blocked_averages [kernel.vmlinux] atomic64_64.h:45  0

```

# REPORT – DISTRIBUTION PARETO

## Shared Cache Line Distribution Pareto

#	Num	HITM		Store Refs		Data address Offset	Pid	Code address	cycles			cpu cnt	Symbol	Shared Object	Source:Line	Node
		Rmt	Lcl	L1 Hit	L1 Miss				rmt hitm	lcl hitm	load					
0	1310	1630	1583	999	0x602100											
	0.76%	0.00%	0.00%	0.00%	0x0	108517	0x400b7a	597	0	1158	1	[.] lock_thd	a.out	false_sharing_example.c:134	0	
	0.15%	0.00%	66.08%	0.00%	0x0	108517	0x400b61	2780	0	1569	1	[.] lock_thd	a.out	false_sharing_example.c:132	0	
	0.00%	0.00%	33.92%	100.00%	0x0	108517	0x400b85	0	0	0	1	[.] lock_thd	a.out	false_sharing_example.c:134	0	
	32.67%	29.02%	0.00%	0.00%	0x8	108517	0x400bab	1100	498	1021	12	[.] reader_thd	a.out	false_sharing_example.c:145	0	1 2 3
	31.68%	41.23%	0.00%	0.00%	0x10	108517	0x400bab	1075	542	1074	11	[.] reader_thd	a.out	false_sharing_example.c:145	0	1 2 3
	34.73%	29.75%	0.00%	0.00%	0x18	108517	0x400bab	1008	429	1077	12	[.] reader_thd	a.out	false_sharing_example.c:145	0	1 2 3
1	1240	1515	3088	178	0x602140											
	0.16%	0.00%	97.51%	0.00%	0x0	108517	0x400b55	1379	0	1441	1	[.] lock_thd	a.out	false_sharing_example.c:131	0	
	0.00%	0.00%	2.49%	100.00%	0x0	108517	0x400b73	0	0	0	1	[.] lock_thd	a.out	false_sharing_example.c:133	0	
	32.66%	30.43%	0.00%	0.00%	0x8	108517	0x400ba0	994	383	998	12	[.] reader_thd	a.out	false_sharing_example.c:144	0	1 2 3
	31.29%	38.02%	0.00%	0.00%	0x10	108517	0x400ba0	1046	423	976	11	[.] reader_thd	a.out	false_sharing_example.c:144	0	1 2 3
	35.89%	31.55%	0.00%	0.00%	0x18	108517	0x400ba0	999	384	1028	12	[.] reader_thd	a.out	false_sharing_example.c:144	0	1 2 3

#	Num	HITM		Store Refs		Data address Offset	Pid	Code address
#		Rmt	Lcl	L1 Hit	L1 Miss			
0	1310	1630	1583	999	0x602100			
		0.76%	0.00%	0.00%	0.00%	0x0	108517	0x400b7a
		0.15%	0.00%	66.08%	0.00%	0x0	108517	0x400b61
		0.00%	0.00%	33.92%	100.00%	0x0	108517	0x400b85
		32.67%	29.02%	0.00%	0.00%	0x8	108517	0x400bab
		31.68%	41.23%	0.00%	0.00%	0x10	108517	0x400bab
		34.73%	29.75%	0.00%	0.00%	0x18	108517	0x400bab

# REPORT – DISTRIBUTION PARETO

```

=====
Shared Cache Line Distribution Pareto
=====
#
# ----- HITM ----- -- Store Refs --      Data address
# Num      Rmt      Lcl      L1 Hit  L1 Miss      Offset
# .....
#
# ----- cycles -----
# rmt hitm  lcl hitm  load
# .....
#
# -----
# 0      1310      1630      1583      999      0x602100
# -----
# 0.76%  0.00%  0.00%  0.00%      0x0  108517      0x400b7a      597      0      1158
# 0.15%  0.00%  66.08%  0.00%      0x0  108517      0x400b61      2780     0      1569
# 0.00%  0.00%  33.92%  100.00%     0x0  108517      0x400b85      0        0      0
# 32.67% 29.02%  0.00%  0.00%      0x8  108517      0x400bab      1100     498    1021
# 31.68% 41.23%  0.00%  0.00%      0x10 108517      0x400bab      1075     542    1074
# 34.73% 29.75%  0.00%  0.00%      0x18 108517      0x400bab      1008     429    1077
# -----
# 1      1240      1515      3088      178      0x602140
# -----
# 0.16%  0.00%  97.51%  0.00%      0x0  108517      0x400b55      1379     0      1441
# 0.00%  0.00%  2.49%  100.00%     0x0  108517      0x400b73      0        0      0
# 32.66% 30.43%  0.00%  0.00%      0x8  108517      0x400ba0      994      383    998
# 31.29% 38.02%  0.00%  0.00%      0x10 108517      0x400ba0      1046     423    976
# 35.89% 31.55%  0.00%  0.00%      0x18 108517      0x400ba0      999      384    1028
# -----
# 2
# -----
# 100.0%
# 0.0%
# 0.0%
# -----
#      cpu      Shared
#      cnt      Object
# -----
#      Symbol      Source:Line      Node
# .....
#
#      1  [.] lock_thd      a.out  false_sharing_example.c:134      0
#      1  [.] lock_thd      a.out  false_sharing_example.c:132      0
#      1  [.] lock_thd      a.out  false_sharing_example.c:134      0
#     12  [.] reader_thd     a.out  false_sharing_example.c:145      0  1  2  3
#     11  [.] reader_thd     a.out  false_sharing_example.c:145      0  1  2  3
#     12  [.] reader_thd     a.out  false_sharing_example.c:145      0  1  2  3
# -----
# compiler.h:243      0  1  3
# atomic64_64.h:45  0  1  2
# atomic64_64.h:45  0

```



# REPORT – DISTRIBUTION PARETO

```

=====
Shared Cache Line Distribution Pareto
=====
#
# ----- HITM ----- -- Store Refs --      Data address
# Num      Rmt      Lcl  L1 Hit  L1 Miss      Offset
# .....
# -----
# 0      1310      1630      1583      999      0x602100
# -----
# 0.76%  0.00%  0.00%  0.00%  0x0  108517  0x400b7a  597  0  1158
# 0.15%  0.00%  0.00%  66.08%  0x0  108517  0x400b61  2780  0  1569
# 0.00%  0.00%  33.92%  100.00%  0x0  108517  0x400b85  0  0  0
# 32.67%  29.02%  0.00%  0.00%  0x8  108517  0x400bab  1100  498  1021
# 31.68%  41.23%  0.00%  0.00%  0x10 108517  0x400bab  1075  542  1074
# 34.73%  29.75%  0.00%  0.00%  0x18 108517  0x400bab  1008  429  1077
# -----
# 1      1240      1515      3088      178      0x602140
# -----
# 0.16%  0.00%  97.51%  0.00%  0x0  108517  0x400b55  1379  0  1441
# 0.00%  0.00%  2.49%  100.00%  0x0  108517  0x400b73  0  0  0
# 32.66%  30.43%  0.00%  0.00%  0x8  108517  0x400ba0  994  383  998
# 31.29%  38.02%  0.00%  0.00%  0x10 108517  0x400ba0  1046  423  976
# 35.89%  31.55%  0.00%  0.00%  0x18 108517  0x400ba0  999  384  1028
# -----
# 2      1      2      2      0      0xffff887bfd04b100
# -----
# 100.00% 100.00%  0.00%  0.00%  0x0
# 0.00%  0.00%  50.00%  0.00%  0x0
# 0.00%  0.00%  50.00%  0.00%  0x0
# -----
# ----- cycles -----
# rmt hitm  lcl hitm  load
# .....
#
# 597  0  1158
# 2780 0  1569
# 0  0  0
# 1100 498 1021
# 1075 542 1074
# 1008 429 1077
# -----
# [k] update_cfs_shares [kernel.vmlinux] compiler.h:243 0 1 3
# [k] task_tick_fair [kernel.vmlinux] atomic64_64.h:45 0 1 2
# [k] update_blocked_averages [kernel.vmlinux] atomic64_64.h:45 0

```

# C2C SPEEDUP EXAMPLE

- perf multi threaded report
- new perf feature by Namhyung Kim
- multiple threads reading/parsing data file
- It is **faster...** of course ;-)

# PERF MULTI THREADED REPORT

Node 0

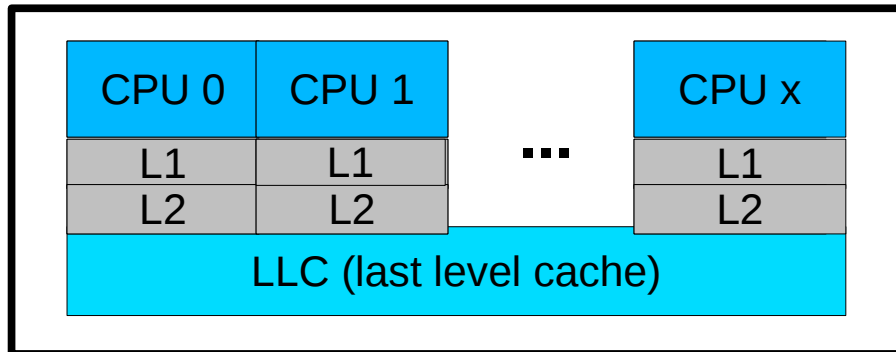

- multi threaded report creates thread on every CPU in system

Node 1

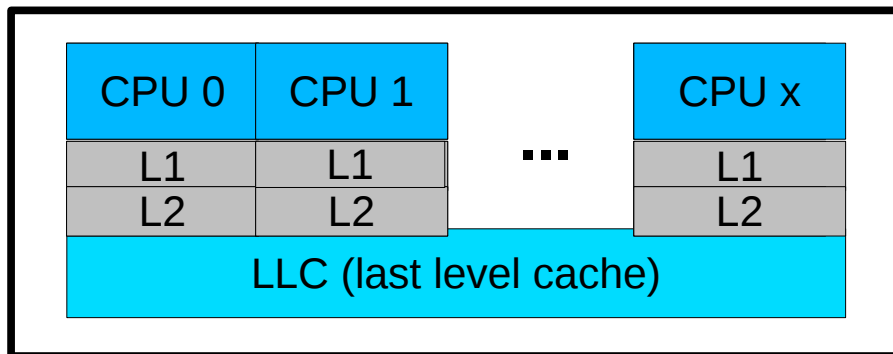

# PERF MULTI THREADED REPORT

Node 0

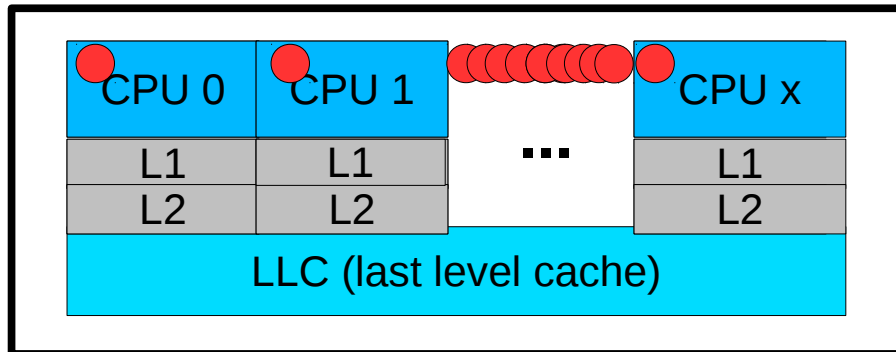

- multi threaded report creates thread on every CPU in system

Node 1

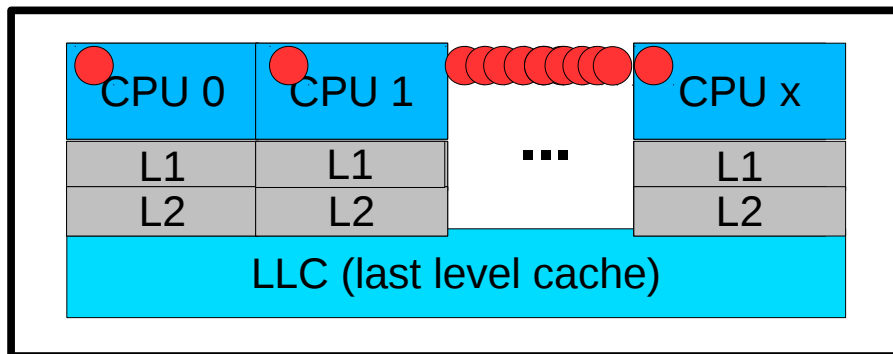

=====  
 Shared Data Cache Line Table  
 =====

#	#	#	Total	Tot	----- LLC Load Hitm -----	----- Store Reference -----	--- Load Dram ---	LLC	Total	----- Core Load Hit -----	-- LLC Load Hit --									
#	Index	Cacheline	records	Hitm	Total	Lcl	Rmt	Total	LlHit	LlMiss	Lcl	Rmt	Ld Miss	Total	Loads	FB	L1	L2	Llc	Rmt
#	.....	.....	.....	.....	.....	.....	.....	.....	.....	.....	.....	.....	.....	.....	.....	.....	.....	.....	.....	.....
#	0	0x2c0d880	5721043	77.20%	44115	43701	414	3686291	3607172	79119	0	145	584	2034752	741904	994452	213480	40631	25	
	1	0x2c0d7c0	189627	6.90%	3942	3870	72	8430	8307	123	0	29	150	181197	31943	97518	45751	1965	49	
	2	0x2c0d800	114597	6.73%	3844	3802	42	6932	4511	2421	0	0	47	107665	88022	6075	9639	80	5	
	3	0x2c2a280	40187	2.80%	1601	1570	31	3494	387	3107	0	0	65	36693	3584	6910	24123	441	34	
	4	0x2c0d8c0	43943	0.07%	40	0	40	0	0	0	0	4	148	43943	1106	11805	27916	2968	104	

Shared Data Cache Line Table

#	Index	Cacheline	Total records	Tot Hitm	----- LLC Load Hitm -----			----- Store Reference -----			--- Load Dram ---			LLC	Total	----- Core Load Hit -----			-- LLC Load Hit --	
#					Total	Lcl	Rmt	Total	LlHit	LlMiss	Lcl	Rmt	Ld Miss	Loads	FB	L1	L2	Llc	Rmt	
#	.....	.....	.....	.....	.....	.....	.....	.....	.....	.....	.....	.....	.....	.....	.....	.....	.....	.....	.....	
	0	0x2c0d880	5721043	77.20%	44115	43701	414	3686291	3607172	79119	0	145	584	2034752	741904	994452	213480	40631	25	
	1	0x2c0d7c0	189627	6.90%	3942	3870	72	8430	8307	123	0	29	150	181197	31943	97518	45751	1965	49	
	2	0x2c0d800	114597	6.73%	3844	3802	42	6932	4511	2421	0	0	47	107665	88022	6075	9639	80	5	
	3	0x2c2a280	40187	2.80%	1601	1570	31	3494	387	3107	0	0	65	36693	3584	6910	24123	441	34	
	4	0x2c0d8c0	43943	0.07%	40	0	40	0	0	0	0	4	148	43943	1106	11805	27916	2968	104	

Total records	Tot Hitm	----- LLC Load Hitm -----			----- Store Reference -----		
.....	.....	Total	Lcl	Rmt	Total	LlHit	LlMiss
5721043	77.20%	44115	43701	414	3686291	3607172	79119
189627	6.90%	3942	3870	72	8430	8307	123
114597	6.73%	3844	3802	42	6932	4511	2421
40187	2.80%	1601	1570	31	3494	387	3107
43943	0.07%	40	0	40	0	0	0

```

=====
Shared Cache Line Distribution Pareto
=====
#
# ----- HITM ----- -- Store Refs -- Data address
# Num Rmt Lcl L1 Hit L1 Miss Offset Pid Code address rmt hitm lcl hitm load cpu Symbol Shared Source:Line Node
# .....
#
-----
0 414 43701 3607172 79119 0x2c0d880
-----
12.80% 13.05% 0.00% 0.00% 0x18 14493 0x4ad298 296 151 364 24 [.] maps_find_by_time perf.old map.c:866 0 1
22.22% 26.02% 27.44% 0.43% 0x20 14493 0x7fa88a71e302 1000 476 612 24 [.] __pthread_rwlock_rdlock libpthread-2.24.so :0 0 1
11.35% 7.94% 10.56% 0.71% 0x20 14493 0x7fa88a71effb 777 466 588 24 [.] __pthread_rwlock_unlock libpthread-2.24.so :0 0 1
2.66% 3.08% 17.78% 0.00% 0x20 14493 0x7fa88a71e35a 784 468 444 24 [.] __pthread_rwlock_rdlock libpthread-2.24.so :0 0 1
3.14% 2.55% 20.26% 0.13% 0x20 14493 0x7fa88a72238f 588 402 438 24 [.] __l1l_lock_wait libpthread-2.24.so :0 0 1
2.90% 2.22% 17.36% 0.00% 0x20 14493 0x7fa88a71f0b5 390 432 471 24 [.] __pthread_rwlock_unlock libpthread-2.24.so :0 0 1
0.00% 0.00% 0.00% 0.00% 0x20 14493 0x7fa88a722393 0 5833 6490 19 [.] __l1l_lock_wait libpthread-2.24.so :0 0 1
0.00% 0.00% 0.00% 0.00% 0x20 14493 0x7fa88a71e307 0 0 5276 14 [.] __pthread_rwlock_rdlock libpthread-2.24.so :0 0 1
0.00% 0.00% 0.00% 0.00% 0x20 14493 0x7fa88a71e35e 0 0 4976 11 [.] __pthread_rwlock_rdlock libpthread-2.24.so :0 0 1
0.00% 0.00% 0.00% 0.00% 0x20 14493 0x7fa88a71efff 0 0 5150 7 [.] __pthread_rwlock_unlock libpthread-2.24.so :0 0 1
0.00% 0.00% 0.00% 0.00% 0x20 14493 0x7fa88a71f0b8 0 0 4946 12 [.] __pthread_rwlock_unlock libpthread-2.24.so :0 0 1
0.00% 0.00% 0.01% 0.38% 0x20 14493 0x7fa88a722412 0 0 0 24 [.] __l1l_unlock_wake libpthread-2.24.so :0 0 1
0.00% 0.31% 0.00% 0.00% 0x24 14493 0x7fa88a71e337 0 152 344 24 [.] __pthread_rwlock_rdlock libpthread-2.24.so :0 0 1
0.24% 0.29% 0.00% 0.00% 0x24 14493 0x7fa88a71f022 733 149 391 24 [.] __pthread_rwlock_unlock libpthread-2.24.so :0 0 1
0.00% 0.16% 0.00% 0.00% 0x24 14493 0x7fa88a71efe1 0 158 480 24 [.] __pthread_rwlock_unlock libpthread-2.24.so :0 0 1
0.00% 0.00% 3.37% 47.01% 0x24 14493 0x7fa88a71e340 0 0 0 24 [.] __pthread_rwlock_rdlock libpthread-2.24.so :0 0 1
0.00% 0.00% 3.22% 51.34% 0x24 14493 0x7fa88a71f02a 0 0 0 24 [.] __pthread_rwlock_unlock libpthread-2.24.so :0 0 1
0.00% 0.01% 0.00% 0.00% 0x30 14493 0x7fa88a71e470 0 174 280 24 [.] __pthread_rwlock_rdlock libpthread-2.24.so :0 0 1
0.00% 0.00% 0.00% 0.00% 0x30 14493 0x7fa88a71f041 0 153 322 24 [.] __pthread_rwlock_unlock libpthread-2.24.so :0 0 1
0.00% 0.21% 0.00% 0.00% 0x34 14493 0x7fa88a71e327 0 170 340 24 [.] __pthread_rwlock_rdlock libpthread-2.24.so :0 0 1
0.00% 0.02% 0.00% 0.00% 0x34 14493 0x7fa88a71f033 0 152 335 24 [.] __pthread_rwlock_unlock libpthread-2.24.so :0 0 1
0.48% 2.59% 0.00% 0.00% 0x38 14493 0x7fa88a71e31f 266 148 340 24 [.] __pthread_rwlock_rdlock libpthread-2.24.so :0 0 1
0.72% 2.14% 0.00% 0.00% 0x38 14493 0x7fa88a71f017 317 146 394 24 [.] __pthread_rwlock_unlock libpthread-2.24.so :0 0 1
0.00% 0.43% 0.00% 0.00% 0x38 14493 0x7fa88a71efd8 0 162 473 24 [.] __pthread_rwlock_unlock libpthread-2.24.so :0 0 1
41.06% 34.16% 0.00% 0.00% 0x3c 14493 0x7fa88a71e2d1 310 146 398 24 [.] __pthread_rwlock_rdlock libpthread-2.24.so :0 0 1
2.42% 4.35% 0.00% 0.00% 0x3c 14493 0x7fa88a71efc0 416 166 481 24 [.] __pthread_rwlock_unlock libpthread-2.24.so :0 0 1
0.00% 0.26% 0.00% 0.00% 0x3c 14493 0x7fa88a71e356 0 194 353 24 [.] __pthread_rwlock_rdlock libpthread-2.24.so :0 0 1
0.00% 0.20% 0.00% 0.00% 0x3c 14493 0x7fa88a71f0b2 0 176 404 24 [.] __pthread_rwlock_unlock libpthread-2.24.so :0 0 1
0.00% 0.00% 0.00% 0.00% 0x3c 14493 0x7fa88a71e35a 0 4983 0 1 [.] __pthread_rwlock_rdlock libpthread-2.24.so :0 0

```

Shared Cache Line Distribution Pareto

#	Num	Rmt	Lcl	L1 Hit	L1 Miss	Data address Offset	Pid	Code address	rmt	hitm	lcl	hitm	load	cpu cnt	Symbol	Shared Object	Source:Line	Node
	0	414	43701	3607172	79119	0x2c0d880												
	12.80%	13.05%	0.00%	0.00%	0.00%	0x18	14493	0x4ad298	296	151	364	24	[.] maps_find_by_time	perf.old	map.c:866	0	1	
	22.22%	26.02%	27.44%	0.43%		0x20	14493	0x7fa88a71e302	1000	476	612	24	[.] pthread_rwlock_rdlock	libpthread-2.24.so	:0	0	1	
	11.35%	7.94%	10.56%	0.71%		0x20	14493	0x7fa88a71e35a	777	466	588	24	[.] pthread_rwlock_unlock	libpthread-2.24.so	:0	0	1	
	2.66%	3.08%	17.78%	0.00%		0x20	14493	0x7fa88a71e35a	784	468	444	24	[.] pthread_rwlock_rdlock	libpthread-2.24.so	:0	0	1	
	3.14%	2.55%	20.26%	0.13%		0x20	14493	0x7fa88a72238f	588	402	438	24	[.] _l1l_lock_wait	libpthread-2.24.so	:0	0	1	
	2.90%	2.22%	17.36%	0.00%		0x20	14493	0x7fa88a71f0b5	390	432	471	24	[.] pthread_rwlock_unlock	libpthread-2.24.so	:0	0	1	
	0.00%	0.00%	0.00%	0.00%		0x20	14493	0x7fa88a722393	0	5833	6490	19	[.] _l1l_lock_wait	libpthread-2.24.so	:0	0	1	
	0.00%	0.00%	0.00%	0.00%		0x20	14493	0x7fa88a71e302	0	0	5276	14	[.] pthread_rwlock_rdlock	libpthread-2.24.so	:0	0	1	
#																		
#																		
#	Num	Rmt	Lcl	L1 Hit	L1 Miss	Data address Offset	Pid											
#	.....	.....	.....	.....	.....	.....	.....											
#																		
	0	414	43701	3607172	79119	0x2c0d880												
	12.80%	13.05%	0.00%	0.00%		0x18	14493											
	22.22%	26.02%	27.44%	0.43%		0x20	14493											
	11.35%	7.94%	10.56%	0.71%		0x20	14493											
	2.66%	3.08%	17.78%	0.00%		0x20	14493											
	3.14%	2.55%	20.26%	0.13%		0x20	14493											
	2.90%	2.22%	17.36%	0.00%		0x20	14493											
	0.00%	0.00%	0.00%	0.00%		0x20	14493											
	0.00%	0.00%	0.00%	0.00%		0x20	14493											
	0.00%	0.00%	0.00%	0.00%		0x20	14493											
	0.00%	0.00%	0.00%	0.00%		0x20	14493											
	0.00%	0.00%	0.00%	0.00%		0x20	14493											
	0.00%	0.00%	0.00%	0.00%		0x20	14493											
	0.00%	0.00%	0.00%	0.00%		0x20	14493											
	0.00%	0.00%	0.00%	0.00%		0x20	14493											
	0.00%	0.00%	0.00%	0.00%		0x24	14493											



-----  
 Shared Cache Line Distribution Pareto  
 -----

#	Num	----- HITM ----- Rmt	Lcl	-- Store Refs -- L1 Hit	L1 Miss	Data address Offset	Pid	Code address	----- cycles ----- rmt hitm lcl hitm	load	cpu cnt	Symbol	Shared Object	Source:Line	Node
#	0	414	43701	3607172	79119	0x2c0d880									
#	12.80%	13.05%	0.00%	0.00%	0x18	14493	0x4ad298	296	151	364	24	[.] maps_find_by_time	perf.old	map.c:866	0 1
#	22.22%	26.02%	27.44%	0.43%	0x20	14493	0x7fa88a71e302	1000	476	612	24	[.] __pthread_rwlock_rdlock	libpthread-2.24.so	.:0	0 1
#	11.35%	7.94%	10.56%	0.71%	0x20	14493	0x7fa88a71effb	777	466	588	24	[.] __pthread_rwlock_unlock	libpthread-2.24.so	.:0	0 1
#	2.66%	3.08%	17.78%	0.00%	0x20	14493	0x7fa88a71e35a	784	468	444	24	[.] __pthread_rwlock_rdlock	libpthread-2.24.so	.:0	0 1
#	3.14%	2.55%	20.26%	0.13%	0x20	14493	0x7fa88a72238f	588	402	438	24	[.] __l1l_lock_wait	libpthread-2.24.so	.:0	0 1
#	2.90%	2.22%	17.36%	0.00%	0x20	14493	0x7fa88a71f0b5	390	432	471	24	[.] __pthread_rwlock_unlock	libpthread-2.24.so	.:0	0 1
#	0.00%	0.00%	0.00%	0.00%	0x20	14493	0x7fa88a722393	0	5833	6490	19	[.] __l1l_lock_wait	libpthread-2.24.so	.:0	0 1
#	0.00%	0.00%	0.00%	0.00%	0x20	14493	0x7fa88a71e307	0	0	5276	14	[.] __pthread_rwlock_rdlock	libpthread-2.24.so	.:0	0 1

cpu cnt	Symbol	Shared Object	Source:Line	Node
.....	.....	.....	.....	.....
24	[.] maps_find_by_time	perf.old	map.c:866	0 1
24	[.] __pthread_rwlock_rdlock	libpthread-2.24.so	.:0	0 1
24	[.] __pthread_rwlock_unlock	libpthread-2.24.so	.:0	0 1
24	[.] __pthread_rwlock_rdlock	libpthread-2.24.so	.:0	0 1
24	[.] __l1l_lock_wait	libpthread-2.24.so	.:0	0 1
24	[.] __pthread_rwlock_unlock	libpthread-2.24.so	.:0	0 1
19	[.] __l1l_lock_wait	libpthread-2.24.so	.:0	0 1
14	[.] __pthread_rwlock_rdlock	libpthread-2.24.so	.:0	0 1
11	[.] __pthread_rwlock_rdlock	libpthread-2.24.so	.:0	0 1
7	[.] __pthread_rwlock_unlock	libpthread-2.24.so	.:0	0 1
12	[.] __pthread_rwlock_unlock	libpthread-2.24.so	.:0	0 1
24	[.] __l1l_unlock_wake	libpthread-2.24.so	.:0	0 1

```
856 struct map *maps__find_by_time(struct maps *maps, u64 ip, u64 timestamp)
857 {
858     struct rb_node **p;
859     struct rb_node *parent = NULL;
860     struct map *m;
861     struct map *best = NULL;
862
863     pthread_rwlock_rdlock(&maps->lock);
864
865     p = &maps->entries.rb_node;
866     while (*p != NULL) {
867         parent = *p;
868         m = rb_entry(parent, struct map, rb_node);
869         if (ip < m->start)
```

map.c

```
struct maps {
    struct rb_root entries;
    pthread_rwlock_t lock;
};
```

map.h

```

856 struct map *maps__find_by_time(struct maps *maps, u64 ip, u64 timestamp)
857 {
858     struct rb_node **p;
859     struct rb_node *parent = NULL;
860     struct map *m;
861     struct map *best = NULL;
862
863     pthread_rwlock_rdlock(&maps->lock);
864
865     p = &maps->entries.rb_node;
866     while (*p != NULL) {
867         parent = *p;
868         m = rb_entry(parent, struct map, rb_node);
869         if (ip < m->start)

```

map.c

```

struct maps {
    struct rb_root entries;
    pthread_rwlock_t lock;
};

```

map.h

```

struct maps {
    struct rb_root entries;
    char u[64];
    pthread_rwlock_t lock;
};

```

- pad members
- use `gcc__attribute__((__aligned__(SMP_CACHE_BYTES)))`

# C2C SPEEDUP EXAMPLE

- results:

BASE – 4000 sec

FIX – 2189 sec (45% faster)

=====  
 Shared Data Cache Line Table  
 =====

#	# Index	Cacheline	Total records	Tot Hitm	----- LLC Load Hitm -----			----- Store Reference -----			--- Load Dram ---			LLC	Total Loads	----- Core Load Hit -----			-- LLC Load Hit --	
#	.....	.....	.....	.....	Total	Lcl	Rmt	Total	LlHit	LlMiss	Lcl	Rmt	Ld Miss	.....	FB	L1	L2	L1c	Rmt	
#	0	0x31af880	5203483	92.68%	63366	62887	479	2999896	2935416	64480	0	150	649	2203587	929482	967733	188052	54784	20	
	1	0x31afa40	218888	6.44%	4406	4366	40	11007	10979	28	0	2	46	207881	119310	66592	8991	8576	4	

=====  
 Shared Data Cache Line Table  
 =====

#	# Index	Cacheline	Total records	Tot Hitm	----- LLC Load Hitm -----			----- Store Reference -----			--- Load Dram ---		LLC	Total	----- Core Load Hit -----			-- LLC Load Hit --	
#	#	#	#	#	Total	Lcl	Rmt	Total	LlHit	LlMiss	Lcl	Rmt	Ld Miss	Loads	FB	L1	L2	Llc	Rmt
	0	0x31af880	5203483	92.68%	63366	62887	479	2999896	2935416	64480	0	150	649	2203587	929482	967733	188052	54784	20
	1	0x31afa40	218888	6.44%	4406	4366	40	11007	10979	28	0	2	46	207881	119310	66592	8991	8576	4

#	# Index	Cacheline	Total records	Tot Hitm	----- LLC Load Hitm -----			----- Store Reference -----		
#	#	#	#	#	Total	Lcl	Rmt	Total	LlHit	LlMiss
	0	0x31af880	5203483	92.68%	63366	62887	479	2999896	2935416	64480
	1	0x31afa40	218888	6.44%	4406	4366	40	11007	10979	28

- ONLY 2 shared cachelines

=====  
 Shared Cache Line Distribution Pareto  
 =====

#	Num	----- HITM -----	--- Store Refs ---	Data address														
#		Rmt	Lcl	Ll Hit	Ll Miss	Offset	Pid	Code address	rmt hitm	lcl hitm	load	cpu		Symbol	Shared	Source:Line	Node	
#												cnt			Object			
	0	479	62887	2935416	64480	0x31af880												
		19.42%	22.58%	29.75%	0.43%	0x20	14709	0x7f8424fed302	948	461	580	24	[.]	__pthread_rwlock_rdlock	libpthread-2.24.so	.:0	0 1	
		15.87%	13.66%	10.42%	1.29%	0x20	14709	0x7f8424fedffb	927	507	620	24	[.]	__pthread_rwlock_unlock	libpthread-2.24.so	.:0	0 1	
		0.42%	2.87%	17.62%	0.00%	0x20	14709	0x7f8424fed35a	778	391	430	24	[.]	__pthread_rwlock_rdlock	libpthread-2.24.so	.:0	0 1	
		2.30%	2.47%	19.00%	0.08%	0x20	14709	0x7f8424fff138f	709	408	422	24	[.]	__l1ll_lock_wait	libpthread-2.24.so	.:0	0 1	
		1.04%	1.96%	17.00%	0.00%	0x20	14709	0x7f8424fee0b5	409	403	451	24	[.]	__pthread_rwlock_unlock	libpthread-2.24.so	.:0	0 1	
		0.00%	0.00%	0.00%	0.00%	0x20	14709	0x7f8424fee0b8	0	5208	4983	15	[.]	__pthread_rwlock_unlock	libpthread-2.24.so	.:0	0 1	
		0.00%	0.00%	0.00%	0.00%	0x20	14709	0x7f8424fff1393	0	4811	5048	14	[.]	__l1ll_lock_wait	libpthread-2.24.so	.:0	0 1	
		0.00%	0.00%	0.00%	0.00%	0x20	14709	0x7f8424fed307	0	0	4993	13	[.]	__pthread_rwlock_rdlock	libpthread-2.24.so	.:0	0 1	
		0.00%	0.00%	0.00%	0.00%	0x20	14709	0x7f8424fed35e	0	0	5223	9	[.]	__pthread_rwlock_rdlock	libpthread-2.24.so	.:0	0 1	
		0.00%	0.00%	0.00%	0.00%	0x20	14709	0x7f8424fedfff	0	0	5706	7	[.]	__pthread_rwlock_unlock	libpthread-2.24.so	.:0	0 1	
		0.00%	0.00%	0.01%	0.63%	0x20	14709	0x7f8424ff1412	0	0	0	24	[.]	__l1ll_unlock_wake	libpthread-2.24.so	.:0	0 1	
		0.00%	0.26%	0.00%	0.00%	0x24	14709	0x7f8424fed337	0	161	332	24	[.]	__pthread_rwlock_rdlock	libpthread-2.24.so	.:0	0 1	
		0.00%	0.23%	0.00%	0.00%	0x24	14709	0x7f8424fee022	0	158	332	24	[.]	__pthread_rwlock_unlock	libpthread-2.24.so	.:0	0 1	
		0.00%	0.09%	0.00%	0.00%	0x24	14709	0x7f8424fedfe1	0	222	383	24	[.]	__pthread_rwlock_unlock	libpthread-2.24.so	.:0	0 1	
		0.00%	0.00%	3.05%	46.84%	0x24	14709	0x7f8424fed340	0	0	0	24	[.]	__pthread_rwlock_rdlock	libpthread-2.24.so	.:0	0 1	
		0.00%	0.00%	3.15%	50.73%	0x24	14709	0x7f8424fee02a	0	0	0	24	[.]	__pthread_rwlock_unlock	libpthread-2.24.so	.:0	0 1	
		0.21%	0.01%	0.00%	0.00%	0x30	14709	0x7f8424fee041	385	244	252	24	[.]	__pthread_rwlock_unlock	libpthread-2.24.so	.:0	0 1	
		0.00%	0.01%	0.00%	0.00%	0x30	14709	0x7f8424fed470	0	360	283	24	[.]	__pthread_rwlock_rdlock	libpthread-2.24.so	.:0	0 1	
		0.00%	0.19%	0.00%	0.00%	0x34	14709	0x7f8424fed327	0	155	331	24	[.]	__pthread_rwlock_rdlock	libpthread-2.24.so	.:0	0 1	
		0.00%	0.01%	0.00%	0.00%	0x34	14709	0x7f8424fee033	0	154	245	24	[.]	__pthread_rwlock_unlock	libpthread-2.24.so	.:0	0 1	
		0.84%	2.73%	0.00%	0.00%	0x38	14709	0x7f8424fed31f	487	151	330	24	[.]	__pthread_rwlock_rdlock	libpthread-2.24.so	.:0	0 1	
		0.42%	1.94%	0.00%	0.00%	0x38	14709	0x7f8424fee017	280	148	331	24	[.]	__pthread_rwlock_unlock	libpthread-2.24.so	.:0	0 1	
		0.21%	0.53%	0.00%	0.00%	0x38	14709	0x7f8424fedfd8	337	183	378	24	[.]	__pthread_rwlock_unlock	libpthread-2.24.so	.:0	0 1	
		43.84%	35.76%	0.00%	0.00%	0x3c	14709	0x7f8424fed2d1	346	151	390	24	[.]	__pthread_rwlock_rdlock	libpthread-2.24.so	.:0	0 1	
		15.03%	14.28%	0.00%	0.00%	0x3c	14709	0x7f8424fedfc0	355	163	392	24	[.]	__pthread_rwlock_unlock	libpthread-2.24.so	.:0	0 1	
		0.21%	0.21%	0.00%	0.00%	0x3c	14709	0x7f8424fee0b2	333	174	341	24	[.]	__pthread_rwlock_unlock	libpthread-2.24.so	.:0	0 1	
		0.21%	0.21%	0.00%	0.00%	0x3c	14709	0x7f8424fed356	315	192	345	24	[.]	__pthread_rwlock_rdlock	libpthread-2.24.so	.:0	0 1	
	1	40	4366	10979	28	0x31afa40												
		0.00%	2.06%	19.54%	0.00%	0x0	14709	0x7f8424fed302	0	321	289	24	[.]	__pthread_rwlock_rdlock	libpthread-2.24.so	.:0	0 1	
		0.00%	1.28%	26.36%	3.57%	0x0	14709	0x7f8424fedffb	0	337	340	24	[.]	__pthread_rwlock_unlock	libpthread-2.24.so	.:0	0 1	
		0.00%	0.39%	18.35%	0.00%	0x0	14709	0x7f8424fee0b5	0	329	304	24	[.]	__pthread_rwlock_unlock	libpthread-2.24.so	.:0	0 1	
		0.00%	0.23%	22.60%	0.00%	0x0	14709	0x7f8424fed35a	0	384	276	24	[.]	__pthread_rwlock_rdlock	libpthread-2.24.so	.:0	0 1	
		0.00%	0.14%	1.99%	0.00%	0x0	14709	0x7f8424fff138f	0	263	269	24	[.]	__l1ll_lock_wait	libpthread-2.24.so	.:0	0 1	
		0.00%	0.00%	0.02%	0.00%	0x0	14709	0x7f8424fed8ec	0	0	122	1	[.]	__pthread_rwlock_wrlock	libpthread-2.24.so	.:0	1	
		0.00%	0.00%	0.02%	0.00%	0x0	14709	0x7f8424fed923	0	0	137	1	[.]	__pthread_rwlock_wrlock	libpthread-2.24.so	.:0	1	
		0.00%	0.00%	0.01%	7.14%	0x0	14709	0x7f8424ff1412	0	0	0	3	[.]	__l1ll_unlock_wake	libpthread-2.24.so	.:0	0 1	
		0.00%	0.05%	0.00%	0.00%	0x4	14709	0x7f8424fedfe1	0	111	246	24	[.]	__pthread_rwlock_unlock	libpthread-2.24.so	.:0	0 1	
		0.00%	0.00%	0.82%	17.86%	0x4	14709	0x7f8424fed340	0	0	0	23	[.]	__pthread_rwlock_rdlock	libpthread-2.24.so	.:0	0 1	
		0.00%	0.00%	10.29%	71.43%	0x4	14709	0x7f8424fee02a	0	0	0	24	[.]	__pthread_rwlock_unlock	libpthread-2.24.so	.:0	0 1	
		0.00%	0.05%	0.00%	0.00%	0x10	14709	0x7f8424fed470	0	136	242	24	[.]	__pthread_rwlock_rdlock	libpthread-2.24.so	.:0	0 1	
		0.00%	0.18%	0.00%	0.00%	0x18	14709	0x7f8424fee017	0	125	254	24	[.]	__pthread_rwlock_unlock	libpthread-2.24.so	.:0	0 1	
		0.00%	0.16%	0.00%	0.00%	0x18	14709	0x7f8424fed31f	0	112	248	24	[.]	__pthread_rwlock_rdlock	libpthread-2.24.so	.:0	0 1	
		0.00%	0.09%	0.00%	0.00%	0x18	14709	0x7f8424fedfd8	0	120	246	24	[.]	__pthread_rwlock_unlock	libpthread-2.24.so	.:0	0 1	
		92.50%	88.52%	0.00%	0.00%	0x1c	14709	0x7f8424fed2d1	271	119	246	24	[.]	__pthread_rwlock_rdlock	libpthread-2.24.so	.:0	0 1	
		2.50%	3.83%	0.00%	0.00%	0x1c	14709	0x7f8424fedfc0	244	118	261	24	[.]	__pthread_rwlock_unlock	libpthread-2.24.so	.:0	0 1	
		0.00%	0.05%	0.00%	0.00%	0x1c	14709	0x7f8424fee0b2	0	155	264	24	[.]	__pthread_rwlock_unlock	libpthread-2.24.so	.:0	0 1	
		5.00%	2.98%	0.00%	0.00%	0x20	14709	0x7f8424fed2e9	286	120	231	24	[.]	__pthread_rwlock_rdlock	libpthread-2.24.so	.:0	0 1	

Shared Cache Line Distribution Pareto

#	Num	HITM Rmt	Lc1	Store Refs L1 Hit	L1 Miss	Data address Offset	Pid	Code address	rmt hitm	cycles lcl hitm	load	cpu cnt	Symbol	Shared Object	Source:Line	Node
#	0	479	62887	2935416	64480	0x31af880										
#		19.42%	22.58%	29.75%	0.43%	0x20	14709	0x7f8424fed302	948	461	580	24	[.] __pthread_rwlock_rdlock	libpthread-2.24.so	::0	0 1
#		15.87%	13.66%	10.42%	1.29%	0x20	14709	0x7f8424fedffb	927	507	620	24	[.] __pthread_rwlock_unlock	libpthread-2.24.so	::0	0 1
#		0.42%	2.87%	17.62%	0.00%	0x20	14709	0x7f8424fed35a	778	391	430	24	[.] __pthread_rwlock_rdlock	libpthread-2.24.so	::0	0 1
#		2.30%	2.47%	19.00%	0.08%	0x20	14709	0x7f8424ff138f	709	408	422	24	[.] __l1l_lock_wait	libpthread-2.24.so	::0	0 1
#		1.04%	1.96%	17.00%	0.00%	0x20	14709	0x7f8424fee0b5	409	403	451	24	[.] __pthread_rwlock_unlock	libpthread-2.24.so	::0	0 1

Symbol	Shared Object	Source:Line
[.] __pthread_rwlock_rdlock	libpthread-2.24.so	::0
[.] __pthread_rwlock_unlock	libpthread-2.24.so	::0
[.] __l1l_lock_wait	libpthread-2.24.so	::0
[.] __pthread_rwlock_unlock	libpthread-2.24.so	::0
[.] __pthread_rwlock_unlock	libpthread-2.24.so	::0
[.] __l1l_lock_wait	libpthread-2.24.so	::0
[.] __pthread_rwlock_rdlock	libpthread-2.24.so	::0
[.] __pthread_rwlock_unlock	libpthread-2.24.so	::0
[.] __l1l_unlock_wake	libpthread-2.24.so	::0
[.] __pthread_rwlock_rdlock	libpthread-2.24.so	::0
...		
[.] __pthread_rwlock_rdlock	libpthread-2.24.so	::0
[.] __pthread_rwlock_rdlock	libpthread-2.24.so	::0
[.] __pthread_rwlock_unlock	libpthread-2.24.so	::0
...		

And both are touching a mutex



# C2C SPEEDUP EXAMPLE

Node 0

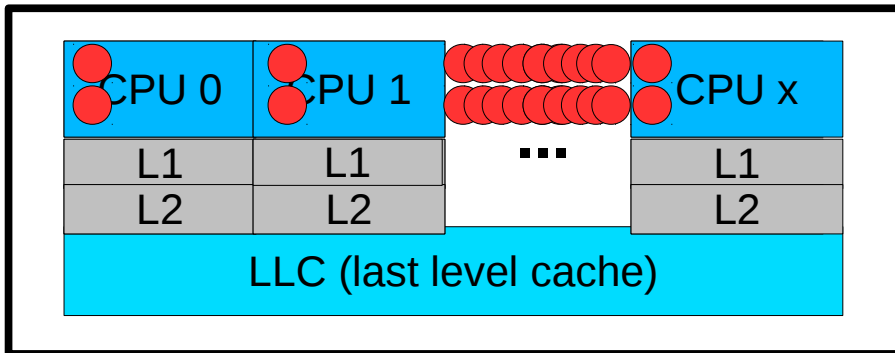

- pin all threads on single socket

Node 1

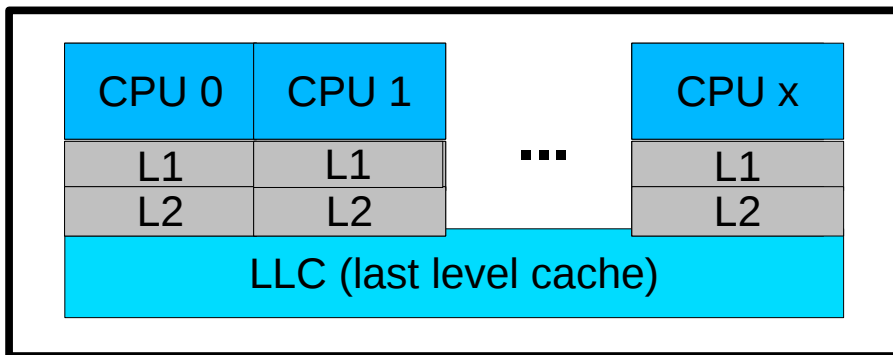

# C2C SPEEDUP EXAMPLE

- results:

BASE – 4000 sec

FIX – 2189 sec (45% faster)

1 SOCKET – 1879 sec (53% faster)

# C2C SPEEDUP EXAMPLE

- multi thread perf report does not scale so well ;-)
- c2c identified showed hot variables
- moving to single socket shows the remote/local HITMs speedup

# Steps to help minimize contention:

- 1) Pack read-only/read-mostly variables together.
- 2) Place the hottest written variables in their own cacheline.
- 3) Pad cachelines as a small tradeoff for reducing contention.
- 4) Align your data/buffers/structs/c++classes on cacheline boundaries.
- 5) Lower the granularity of locks (lock smaller chunks of data to reduce contention).
- 6) Use compile-time asserts to guarantee struct member alignment:

# Questions



# Random Tips

To align dynamically allocated C++ classes on a cacheline boundary:

Change:

```
foo *ctx = new Foo(this, tid);
```

to:

```
void *p = aligned_alloc (64, sizeof(Foo));  
foo *ctx = new (p) Foo(this, tid);
```

The above ensures the beginning of the class is allocated on a cacheline boundary. And then use "`__attribute__((aligned (64)))`" on individual class members needing cacheline alignment.

C2C prototype copy available at:

[http://people.redhat.com/jmario/rhel7\\_c2c/perf.rhel7.c2c](http://people.redhat.com/jmario/rhel7_c2c/perf.rhel7.c2c)

Extensive usage info in blog at:

<https://joemario.github.io/>

# Random Tips

To get more HITMs play with record options:

**-F** <freq>            perf record  
**-l** <latency>        perf c2c record

Higher frequency and latency settings generate more **HITMs** events.

Check following files:

```
echo 100000 > /proc/sys/kernel/perf_event_max_sample_rate  
echo 100 > /proc/sys/kernel/perf_cpu_time_max_percent
```